

DD3000
10601RE-US – 460V / 3PH / 60HZ

INDUSTRIAL DEHUMIDIFIER

OWNER'S MANUAL



www.eipl.co.uk

1. INTRODUCTION

Page	Contents:
3	1. Introduction
3	1.1 Handling
3	1.2 Contents of Crate
3	1.3 Principle of Operation
4	1.4 Typical Applications
5	2. Specification
7	3. Layout
7	3.1 Duct Connections
7	3.2 Exploded View
8	4. Capacity Diagram
9	5. Installation
9	5.1 Connecting Ducts
9	5.2 Electrical Supply
10	5.3 Humidity Control
11	6. Commissioning
12	7. Operation
13	7.1 Electronic Controller
14	7.2 Process Fan speed Control
15	7.3 Indicators
16	7.4 Safety
17	8. Maintenance
18	9. Fault Finding
20	10. Service / Repair
22	11. Fan Performance Curves
24	12. Electrical Details
24	12.1 Electrical Component Details

Additional Info

Drawing	
2062132	Principle of Operation
2060158	General Assembly View
2060159	Internal View
5010416	Wiring Diagram
5020416	Wiring Schematic

Data Sheets	
	Process Fan
	Regeneration Fan
	Drive Motor
	Electronic Controller

Dehumidifiers are required wherever there is a need to lower the humidity level to prevent corrosion, mold growth and condensation or maintain a low humidity condition during manufacture, packaging or storing of hygroscopic products.

The DD3000 desiccant dehumidifier is a robust unit that has been designed to combine exceptional performance with high reliability and strength.

The unit incorporates a resistive heater ensuring maximum drying is immediately reached and constantly maintained while the unit is running. Manual / Automatic control is a standard feature, and a remote humidistat can quickly and easily be connected for automatic operation and control

1.1 Handling

Carefully remove the DD3000 dehumidifier unit from its transit crate and visually check for signs of damage.

WARNING
VERY HEAVY ITEM!

If there is evidence of damage DO NOT attempt to operate the unit, call your supplier for advice. Do not discard the packing; it will be useful when transporting the dehumidifier unit in the future.

A truck can be used to move and position the dehumidifier. Lifting points have been provided in the skirt to position suitable forks to lift the unit. The total weight is 565Kg

1.2 Contents of Crate

Item	Description	Quantity
10601RE-US	Dehumidifier	1
TPC465	User Manual	1

1.3 Principle of Operation

The DD3000 is of the desiccant wheel type designed to dry air by passing a large volume of air, the “process” air through a slowly rotating Silica gel rotor. Silica gel is a hygroscopic material that absorbs moisture direct from the air. As the air passes through the rotor the humidity of the air is reduced, whilst the moisture content of the rotor is increased. A smaller volume of air, the reactivation air, is heated by an internal heater and passes through a portion of the rotor in the opposite direction. As this heated air passes through the rotor it will “reactivate” it by removing the moisture content from the silica gel material.

The reactivation air will leave the humidifier as warm, moist air and must be vented to outside of the building. This is also shown on diagram 2062132.

Continuous circulation of the air through the dehumidifier unit gradually reduces the relative humidity in the space. Please see diagram 2062132 for a representation of this process.

1.4 Typical Applications

The EIPL range of large desiccant dehumidifiers is intended for indoor use only, for fixed installations. This can be to control the humidity in storage facilities, in manufacturing processes, during food and drink manufacture and many more areas where low levels of humidity are needed.

These units can also be used to form part of a larger air handling system. However, care must be taken to ensure the pressure in the main system does not adversely affect the performance of the dehumidifier – Contact EIPL for further information.

Air filters are provided, but as far as practicable, the air being processed should be free from pollution and other solid particles. Air containing solvents and other potentially explosive mixtures should not be allowed to enter the unit.

The DD3000 is designed to work under the following conditions:

Maximum Ambient Temperature	35°C (95°F)
Maximum Relative Humidity	100%
Atmospheric Pressure	Atmospheric +/-500 Pa

2. SPECIFICATION

General data:

Process air flow, max	3500m ³ /h
Process airflow, nominal	3000m ³ /h
Regeneration air flow, nominal	720m ³ /h
Nominal Capacity @ 27°C 60% RH	477 litre/24h

Process air fan

Make: EBM, type K3G400-PI92-05	
Static Pressure	800Pa
Power Input	2500W
Speed (*via potentiometer in control panel)	2450 rpm *
Weight	27Kg
Detailed specification can be found in Section 13.1	

Regen. air fan

Make: ACI, Type VBW6-00460	
Static Pressure	800Pa
Power Input	750W
Speed	3520
Weight	14.0Kg
Detailed specification can be found in Section 13.2	

Drive motor

Make: Minimotor, Type ACE 72T (i=1227.5)	
Motor	23W 0.13A
Output speed	2.64 rpm
Weight	3.0Kg

Electric heater

12 x 2000W wired in delta series by 2
Heater groups 2
Group 2: 12kW SSR Relay controlled
Group 1: 12kW On/Off control (relay)
All groups controlled by electronic controller

Other information

Rotor	650mm dia x 200mm
Rotor speed	12 rph



Drawing No.	:- TPC465
Issue	:- 1
Date	:- 16/04/25

Dimensions

L x W x H (See Section 3: Layout for details)

Weight

565Kg

Electrical data

Voltage

460V 3ph + PE

Heater elements

24kW : 460V

Process fan

2.4kW : 380-480V

Regen. fan

0.75 kW : 460V

Drive motor

0.023kW : 460V

Control circuit

420VA Max – 230V

Total power

28kW

External fuse rating

63A



Drawing No.	:- TPC465
Issue	:- 1
Date	:- 16/04/25

3. LAYOUT

Please see diagram 2060158 sheet 1 of 2 for a general overview of the unit.

3.1 Duct Connections

Please see diagram 2060158 sheet 2 of 2 for the duct interface mounting points.

3.2 Exploded view

Please diagram 2060159 for an internal view of the unit showing the major components.

4 CAPACITY DIAGRAM

How much moisture the dehumidifier will remove depends on the temperature and relative humidity of the “process” air onto the unit.

The diagram below shows how much water will be removed:

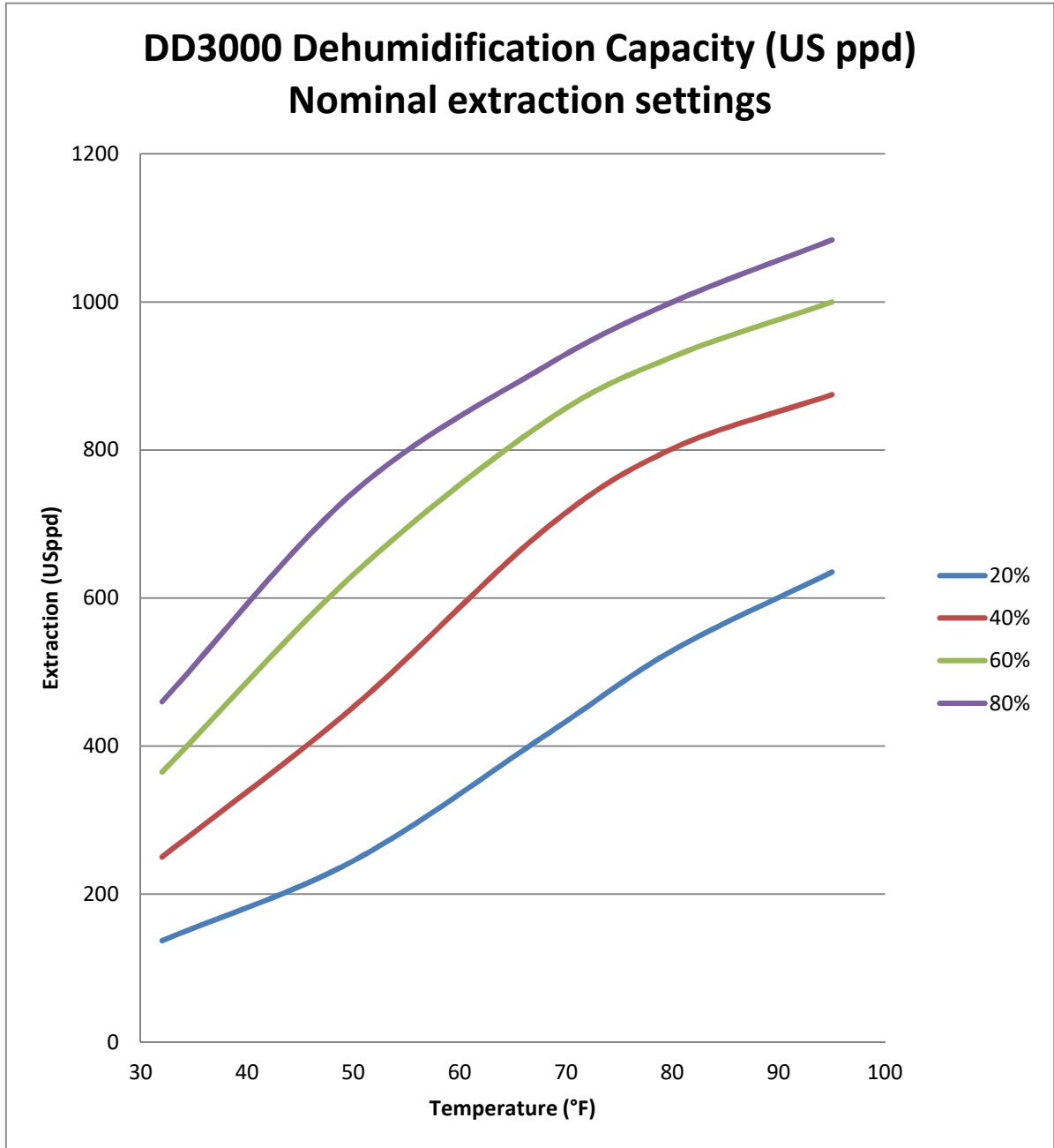

Example:

If the inlet “Process” temperature is 60°F and the relative humidity is 60%, then the amount of moisture removed per day is 750 pints.

5.0 INSTALLATION

The dehumidifier is intended for indoor use only. It should be placed on a level floor. If required, shock absorbers can be placed under the cabinet to reduce excess noise and vibration.

The back side of the unit can be placed against a wall, allowing 0.5m clearance. The remaining three sides of the cabinet must have at least 1m clearance to any adjacent surface to allow access for routine maintenance and service

5.1 Connecting Ducts (Refer to section 3.1 for detailed drawing)

Regeneration air

The regeneration air is taken from outside of the room and should be discharged to outside of the room also. For this reason it is recommended that the dehumidifier is positioned near an outer wall through which these connections can be made.

Regeneration Air Inlet - duct connection size (438mm x 438mm free area with 20mm flange all round)

A filter is provided and must be fitted at all times.

Regeneration Air Outlet - duct connection size (250mm diameter)

Condensation may form in the duct. For this reason the duct must be installed with a slight gradient to allow the water to run away from the dehumidifier and out of the duct. If this is not possible then a small drain hole (6mm diameter) must be drilled at the lowest point of the duct.

A damper must be installed in the duct to adjust the regeneration air flow to its optimum value.

Process air

Process Air Inlet – duct connection size (698mm x x498mm free area with 20mm flange all round)

A filter is provided and must be fitted at all times.

Process Air Outlet - duct connection size (400mm diameter)

Sizing of the duct must be made taking into account the maximum external pressure available from the fan.

5.2 Electrical Supply

The unit must be connected to a suitable 460V, 3 phase + PE, 60Hz supply.

<p>-WARNING-</p> <p>THIS APPLIANCE MUST BE EARTHED</p>
--

Maximum power consumption is 28kW.

Recommended external fuse protection 63A

Feed the power cables through a suitable gland and then wire the unit as shown below.

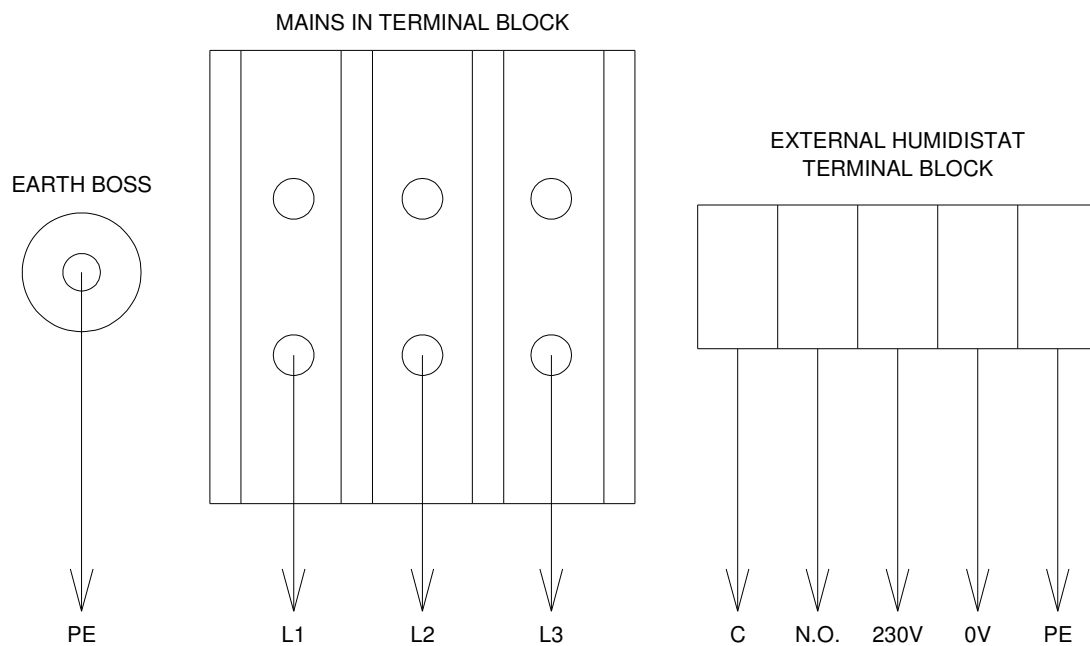

5.3 Humidity Control

An external humidistat can be used to control the relative humidity in the dehumidified area. If a humidistat is used, the wires should pass through a suitable gland and then be wired as shown above. If an electronic humidistat is used, an external 230V 60Hz supply is provided. The total load should not exceed 1.0 Amp

6.0 COMMISSIONING

WARNING

REMOVAL OF COVERS AND PANELS WILL ALLOW ACCESS TO LIVE PARTS AND ROTATING FAN BLADES

THIS WORK MUST ONLY BE CARRIED OUT BY SUITABLY QUALIFIED PERSONNEL

Check installation

- Ensure the dehumidifier is installed with adequate clearance around the unit to allow access for service and maintenance.
- Ensure all controls are in the OFF position – including MCB's located in control panel
- Checking supply cable is correctly sized and installed according to Section 5.2. Ensure earth connection is secure.
- Check supply voltage between phases L1, L2 & L3 (460V)
- If a remote humidistat is fitted, check it is wired correctly.

Duct work

- Check damper has been installed in the regeneration outlet duct, and duct is vented outside the building.
- Check regeneration outlet duct is installed to allow condensate water to drain away from the machine (If not ensure drain hole is available at lowest point)
- Check regeneration damper is fully opened

Dehumidifier Start Up

- Open the control panel:
 - Switch on 63A switch CBM
 - Switch on CB1 (10A), CB4 (6A), CB5 (6A) & CB6 (6A)
- Switch on Main Isolator
- Ensure temperature control is illuminated with set point at 110°C
- Check Process Fan Speed on controller is set at 75%
- Switch on the function selector to required operating mode
 - "MAN" for continuous operation
 - "AUTO" for automatic control by means of external humidistat (if fitted) Adjust control to the lowest humidity setting to ensure DD3000 operates
- Press the Start button and check the following:
 - Process fan motor starts
 - Regeneration motor starts
 - Desiccant rotor is turning
 - No fault lights are illuminated – Process Motor Stopped indicator will be illuminated
 - Both the ON and DRYING indicators are illuminated
 - Heating indicator sequence begins (heater banks should illuminate one after the other after a small delay – max 30 seconds between heating stages)

- Check air flows:
 - The process air flow is factory preset to 3000m³/h (1766CFM). However, depending on design of attached ductworks; the air flow may need to be adjusted.
 - Using a suitable instrument (Pitot tube, anemometer etc....) adjust the Process Motor Speed control, located within control panel, until the correct airflow is achieved.
 - To set the regeneration airflow to the nominal 720m³/h (424CFM), adjust the damper in the duct outlet until the required airflow is achieved – further adjustment may be necessary to achieve the correct temperature, see below
- Switch on Heaters:
 - Switch on CB2 (25A) & CB3 (25A)
 - Check that the temperature shown on the controller TC1 begins to rise.
 - Carry out the final adjustment on the regeneration air flow. Ensure that correct temperature is achieved – this should be 110°C at 20°C (typically 90K temperature rise above the air on temperature) Ensure heater stage indicator 1 is permanently ON and stage 2 cycles ON/OFF.
 - If the correct temperature cannot be achieved then the air flow is too high and the damper should be closed.
 - If the temperature is achieved and stage 2 is permanently OFF then the airflow is too low and should be increased by adjustment of the damper - opening.

The unit is now ready to be used. The dehumidifier will now operate automatically and the humidity in the space will gradually reduce.

7.0 OPERATION

An isolating switch is provided on the front of the panel to switch the unit ON or OFF

The DD3000 has two modes of operation:

- **Manual** – the unit operates continually
- **Auto** – The unit is controlled by an external humidistat, allowing the relative humidity in the conditioned space to be maintained at the required level.

To start the dehumidifier, switch the isolator to the ON position and turn the selector switch to the required mode. If AUTO is selected, ensure the external humidistat is set to the lowest humidity value.

After a slight delay, the fans will operate – air can be felt blowing from the air outlets.

Ensure that the ON indicator and the DRYING indicator are illuminated.

The two HEATING stage indicators should also illuminate and the temperature shown on the electronic controller will increase.

When this temperature reaches the set point, the STAGE 2 HEATING indicator will start to cycle on and off to maintain the required set temperature.

When the humidity in the space reaches the required level (AUTO mode) the DRYING indicator will switch off.

Note: When the dehumidifier is switched OFF, or, in AUTO mode when the required humidity is achieved and DRYING is no longer required, the fans may continue to operate for a short period of time to cool the machine to a suitable level.

7.1 Electronic Controller

The electronic controller is a programmable PID controller with touch screen. Its primary function is to accurately control the temperature of the heated air onto the desiccant rotor. The display shows both the SET POINT temperature and the ACTUAL temperature (AIR ONTO ROTOR) in the heated duct. For normal operation the SET POINT should be set at 90K above the process air inlet – i.e. if the process air entering the machine is at 20°C then the SET POINT should be set at 110°C.

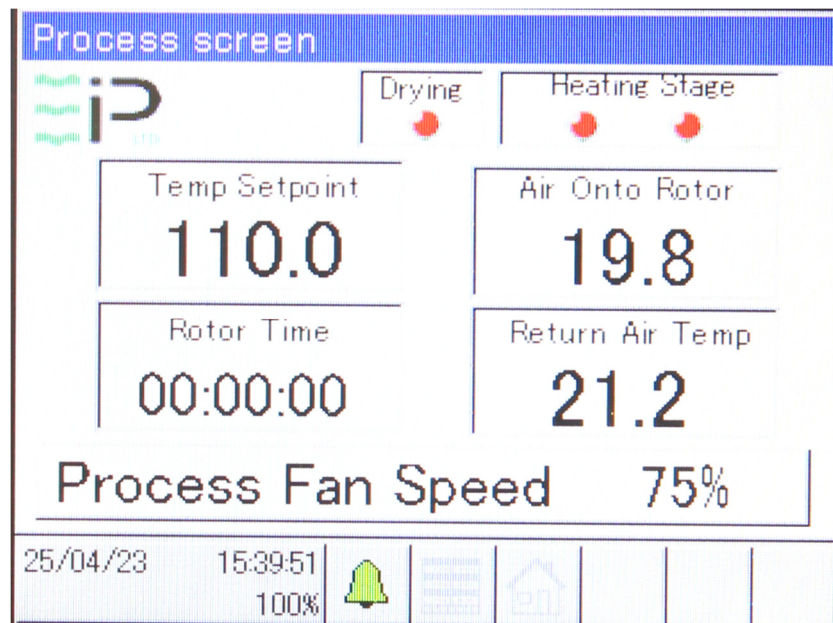

TEMP SETPOINT – This is the target heater temperature to achieve optimum drying – normal set at 90K above the ambient air temperature.

To adjust the set point, touch the TEMP SETPOINT icon on the screen. This will open a “pop-up” window that allows the new value to be entered. Simply type the new temperature (maximum value 125°C) and then press return (Green Arrow) and the new value will be stored and displayed on the Process Screen.

AIR ONTO ROTOR – This is the actual heater temperature within the duct. In normal use this should be similar to the set point

ROTOR TIME – The DD3000 is equipped with “rotor detection” to ensure that the Desiccant rotor is turning and operating correctly. The controller is programmed to show an ALARM if the time for one revolution of the rotor exceeds a pre-set time. If the ROTOR TIME counter reaches ZERO the controller assumes there is a problem with the desiccant rotor and displays an alarm. In normal use the ROTOR TIME is automatically reset after every revolution.

In the event of a fault with the rotor, the GREEN alarm icon will turn RED and a warning ROTOR SPEED TIMED OUT will be displayed on the screen. This information will also be stored in the ALARM LIST. To reset the ALARM, simply touch the ALARM icon on the screen and select ALARM LIST – this should show more information on the alarm. Touch CONFIRM (untick box) and then press BACK to return to the Process Screen. The ALARM has now been reset.

RETURN AIR TEMP – This is the temperature of the processed air returning to the conditioned space – this is normally 10 to 15° higher than the ambient air entering the machine.

DRYING / HEATING STAGE indicators – These change from RED to GREEN when drying and each heating stage is in operation.

PROCESS FAN SPEED – The main process motor is an EC Variable speed fan. The speed can be adjusted from 0 to 100%. To adjust the speed, touch the PROCESS FAN SPEED icon on the screen. This will open a “pop-up” window that allows the new value to be entered. Simply type the new speed and then press return (Green Arrow) and the new value will be stored and displayed on the Process Screen.

Further info on the effect of changes in process air flow can be found in section 7.3

Additional information can be viewed by touching the Date / Time icons. All of the information relating to the controller software program is Write Protected and cannot be changed. However, certain parameters i.e. date and time etc...can be changed and updated

7.2 Process Motor Speed Control

The DD3000 is fitted with an EC variable speed motor. This allows the volume of processed air passing over the Silica Rotor to be adjusted depending on the type of drying required.

The fan speed can be adjusted using the Electronic Controller.

If a high level of moisture extraction is required, it will be necessary to increase the airflow – press the “plus” indicator ion the screen.

If lower humidity levels are required then the process airflow should be reduced - press the “minus” indicator ion the screen.

The following table should be used as a guide.

	Process air flow (m ³ /h)
Standard Operation	3000
High Extraction	3500
Deep Drying (Low RH)	2500

7.3 Indicators

An hour counter is provided to display the total time the unit has been in operation – only operates when dehumidifier is DRYING.

Illuminated push buttons indicate if the dehumidifier is ON (green) or OFF (red)

The DRYING indicator (green) should always be illuminated in MANUAL mode. This shows that the dehumidifier is working correctly and constantly drying the space.

In AUTO mode, the DRYING indicator will cycle ON / OFF as the required humidity in the space is achieved or further drying is required (controlled by external humidistat).

2 x HEAT ON indicators are provided, one for each stage. When the unit is first switched on these will illuminate in sequence 1 then 2 until all are illuminated. On start up, there is a 15 second time delay between each stage of heating operating. When the correct temperature is achieved, STAGE 2 heating will cycle ON / OFF depending on the demand for heating.

3 x FAULT (red) indicators are provided. These will only illuminate if a fault develops within the dehumidifier. These indicators are:

- PROCESS FAN STOPPED – the main fan is not working correctly / stopped
- OVERLOAD FAULT – one of the motor protection devices has operated
- HIGH TEMPERATURE FAULT – the duct heater safety device has operated

Further information on the causes of these fault indicators can be found in SECTION 9 – FAULT FINDING.

7.4 Safety

The DD3000 has been designed to work in ambient conditions of -20°C to +35°C. Should the temperature in the room become excessive then an overheat protector will operate, switching off the heaters. The fans and drive motor will continue to operate But the HIGH TEMPERATURE fault light will illuminate.

The HIGH TEMPERATURE fault light may also illuminate if the regeneration airflow is too low as a result of being incorrectly set, incorrect sizing of duct work or blocked filter.

All of the components installed in the control panel are protected by Circuit Breakers. In the event of an electrical failure of any of these parts, one or more of the Circuit Breakers will “trip” rendering that part of the circuit safe.

All of the motors are equipped with “overload” protection. In the event of a motor failure or increased or unexpected loading on these motors i.e. jammed or locked rotors, faulty drives etc...the overload will operate, cutting power and protecting the motor from damage.

The process motor is fitted with its own internal protector which will operate if it detects any unusual behaviour from the motor or its associated electronic speed control circuitry.

WARNING

- **DO NOT** OPERATE THE MACHINE WITH ANY COVERS REMOVED AS THIS WILL ALLOW ACCESS TO LIVE PARTS AND ROTATING FAN BLADES.
- REPAIRS SHOULD ONLY BE CARRIED OUT BY SUITABLY QUALIFIED PERSONNEL.
- **DO NOT** USE IN AN ENVIRONMENT CONTAINING FLAMMABLE GASES.
- **DO NOT** USE THIS UNIT IF ANY OF THE PANELS OR SUPPLY WIRING IS DAMAGED.
- **DO NOT** INSERT ANY OBJECTS INTO ANY OF THE GRILLES ON THE MACHINE.
- **DO NOT** COVER OR OBSTRUCT AIRFLOW TO AND FROM THE UNIT – ENSURE CORRECT FILTERS ARE USED AND REGULARLY INSPECTED / REPLACED WHEN REQUIRED.
- **DO NOT** STAND ON THE UNIT.
- **DO NOT** ALLOW CHILDREN TO PLAY WITH OR AROUND THE UNIT. ENSURE THE UNIT IS INACCESSIBLE TO CHILDREN WHEN NOT ATTENDED.
- **ENSURE** SUPPLY CABLE SIZE IS CORRECTLY SIZED AND OVER-CURRENT PROTECTION MATCHES THE UNIT
- **ENSURE** THE MACHINE IS CONNECTED TO A RELIABLE EARTH.
- **ENSURE** A RESIDUAL CURRENT DEVICE (RCD) IS USED
- **ENSURE** THE UNIT IS KEPT DRY. NEVER USE A HOSE OR PRESSURE WASHER TO CLEAN THE UNIT
- **ONLY** USE THE DEHUMIDIFIER FOR THE PURPOSE FOR WHICH IT IS DESIGNED

8.0 MAINTENANCE

WARNING

ANY MAINTENANCE, FAULT FINDING OR SERVICING & REPAIR OF THIS DEHUMIDIFIER MUST ONLY BE CARRIED OUT BY A SUITABLY QUALIFIED PERSON.

REMOVAL OF COVERS ALLOWS ACCESS TO LIVE PARTS AND ROTATING BLADES

The DD3000 is designed to operate with the minimum of maintenance. It is recommended that the following MONTHLY checks are completed, and an ANNUAL inspection / service is carried out.

Monthly

- Check the cooling fan in the control panel door is operating correctly – check and replace filter if required.
- Check the Rotor is turning – remove a single panel to view wheel is turning (time for one revolution is approx 5 minutes).
- Check both fans are operating
- Check setting of electronic controller (90K above ambient)
- Check heating indicators are cycling ON/OFF
- Check NO fault indicators are illuminated.

Annually - Switch OFF the machine and check the following – it may be necessary to remove several panels to carry out this inspection

- Check the condition of the Rotor drive belts
- Check condition of Rotor seal – ensure a good all round seal between rotor and mounting frame
- Check internal flexible hose for signs of air leaks
- Check all earth connections are attached and secured tightly.
- Check all internal wiring for signs of over-heating / mechanical damage.
- Check all components in the control panel for signs of damage – check ALL MCBs are ON
- Check fan blades rotate freely
- Check condition of heating elements – no signs of corrosion or damage.
- Process Motor – refer to Manufacturers operating instruction for correct maintenance and fault finding guide (included)

Refit the panels and check the function and correct settings for dehumidifier – Refer to Section 6.0 COMMISSIONING for correct procedure.

9.0 FAULT FINDING

RED Fault Indicators:

- **PROCESS FAN FAULT**

The process fan is fitted with an internal alarm relay. This can operate for a number of reasons – overheating, power failure, sensor failure etc...: Check

- With power switched OFF does fan blade spin freely
- With power connected is motor wired correctly / any loose connections
- Is 3 phase supply present – 460V 3 ph 60Hz
- Is 10Vdc control signal present

Refer to manufacturers operating instructions – included

- **OVERLOAD FAULT**

Each of the three motors – Process, Drive and Regeneration are protected by thermal overloads. If any of these operate then the FAULT light will illuminate. The overloads are located in side the control panel – refer to wiring diagram.

To identify which overload has operated open control panel door and check each overload individually – visual inspection. Once identified, press the reset button and re-start the machine. If the fault persists check the relevant motor for faults.

Also check the running current of the motors and also that the overloads are set correctly.

- **HIGH TEMPERATURE FAULT**

The dehumidifier has two over temperature sensor located in the heater duct. These operate when the temperature in the duct exceeds 140°C. If this indicator is illuminated check the following:

- Regeneration airflow is correct
- Condition of filter – change if in doubt
- Fan is working
- Duct work is sized correctly
- Correct setting of OHP (located in heater box panel behind main control panel).

STARTING the dehumidifier.

If the machine does not start when the START button is pressed

- Check voltage supply / main isolator SW1 is switched on
- Check all MCB's are on
- Check output voltage from transformer TX1 - 220V
- Check if any fault indicators are illuminated and rectify – see above
- Check time delay relay TD1 is set correctly >2 seconds
- Check control relays RLA, RLB & RLC are working correctly
- Check ON indicator is illuminated
- Check AUTO / MANUAL switch and external humidistat (if fitted) are set correctly
- Check Controller TC1 is operating correctly – Drying indicator is Green

NO HEATING.

If the fans operate and rotor is turning but there is no heating, check:

- MCB's CB2 & CB3 are on
- Controller TC1 is set correctly
- Temperature sensor is showing the correct temperature and is working correctly
- Regeneration airflow is correct.

ROTOR NOT TURNING

If the desiccant rotor does not turn, check:

- Drive belt tension is correct and is not slipping
- Drive belt is not broken
- The rotor is not jammed
- Drive motor overload has not tripped
- Drive motor is working correctly.

NO DRYING

If the drying indicator is illuminated but there is little or no drying of the conditioned space, check:

- Correct airflow – both regeneration and process air
- Heaters are working – see above
- Rotor is turning – see above
- Condition of filters – not clogged
- Air leakage – check internal seals, duct work and all panels are fitted.

NOISY

If the dehumidifier is noisy check:

- Fans are secured tightly
- No loose fixings
- Machine is level
- Additional sound dampening of the external duct work is required.

10.0 SERVICE / REPAIR

This machine should only be serviced by qualified Ebac Industrial Products Ltd personnel or other persons having technical competence in servicing electrical equipment following the instructions in this manual

All electrical controls (circuit breakers, contactors, overloads etc....) are located in the control panel. To gain access open the door and refer to wiring information for location of key components.

The remaining parts – fans, heaters, gear motors... can only be accessed when external panels are removed.

Rotor assembly

The rotor itself is maintenance free. However, should it be necessary to clean the rotor, compressed air should be used to carefully blow dirt from the rotor.

To replace the rotor gasket:

- Ensure the machine is isolated from the mains supply
- Remove the outer panels in the centre of the machine
- Loosen the strap holding the seal in place
- Remove seal.
- Refit seal and tighten.

To replace the drive belt:

- Ensure the machine is isolated from the mains supply
- Remove the outer panels in the centre of the machine
- Loosen the bolts holding the drive motor in place
- Loosen the grub screws securing shaft to bearings and pulley
- Carefully withdraw the motor / shaft assembly taking care to support motor wiring
- Place a support under the rotor to hold it in place
- Remove the 2 x M10 bolts holding the rotor shaft in place
- Remove shaft taking care not to lose internal spacers
- The drive belt can now be removed and replaced

Electric Heaters

The heating elements are maintenance free. However, should it be necessary to clean the heaters, compressed air should be used to carefully blow dirt from the elements.

To replace an element it is necessary to gain access to the complete heater assembly:

- Ensure the machine is isolated from the mains supply
- Remove the outer panels in the centre of the machine
- Loosen the bolts that hold the control panel in place – the panel is hinged to allow access to the heater box.
- Remove the bolts that hold the heating box to the duct and gently ease the assembly out
- Disconnect wiring from the damaged element and replace.

Fan motors

To replace a fan motor:

- Ensure the machine is isolated from the mains supply
- Remove the outer panels from the ends of the machine where the fans are located
- Remove attached duct work – including flexible hoses if applicable
- Remove electrical wiring from motor terminal box
- Remove fixings and replace fan motor
- After the fan motor has been replaced, check direction of rotation is correct. If wrong, swap any two electrical phases in the motor terminal box.

Should any electrical component fail, consult the Factory Service Centre to obtain the correct replacement part.

11.0 FAN PERFORMANCE CURVES

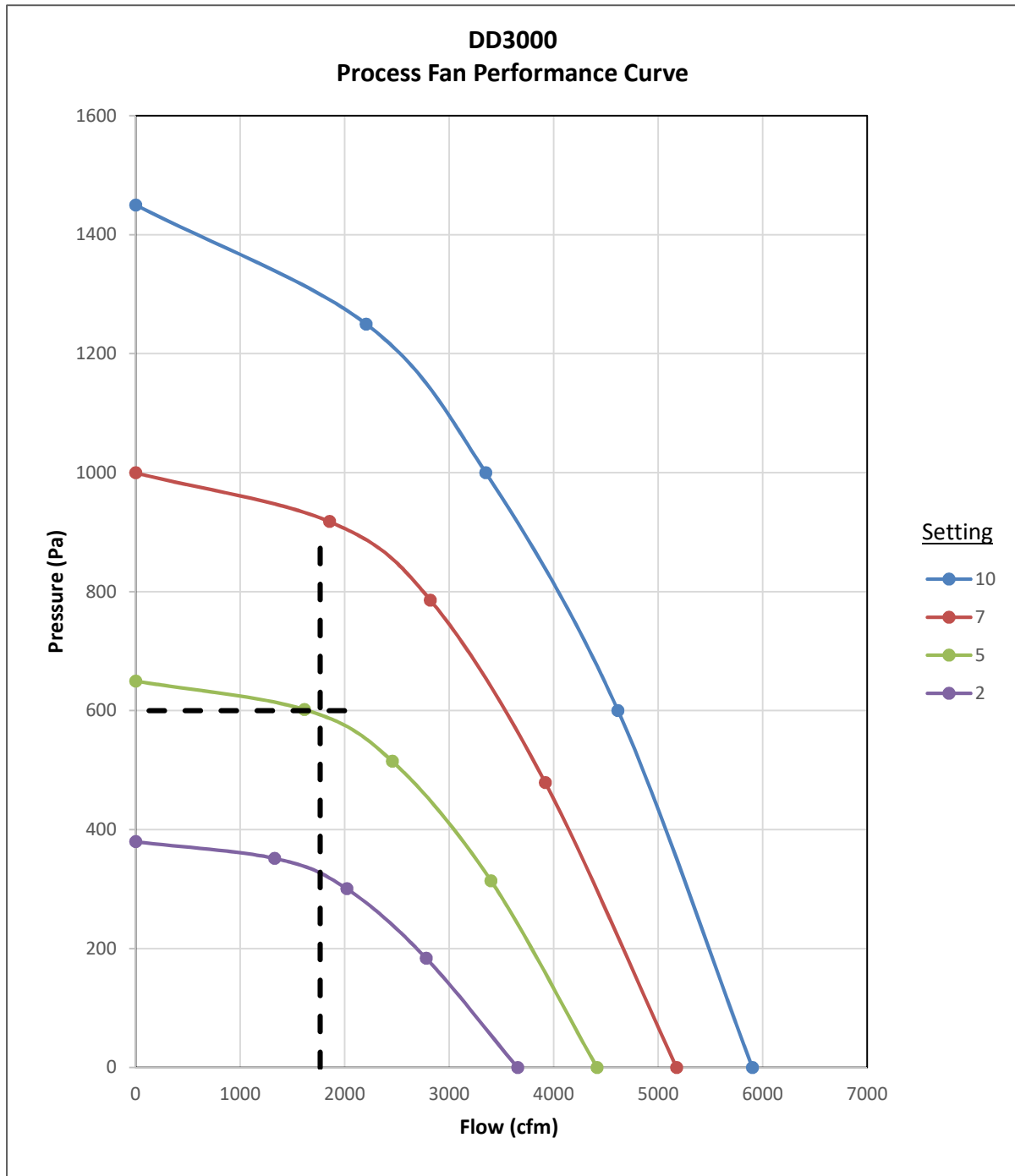

For example:

If the total system resistance is 600pa then the process speed control would have to be set to 5 to achieve the required airflow of 3000m³/h (1765cfm)

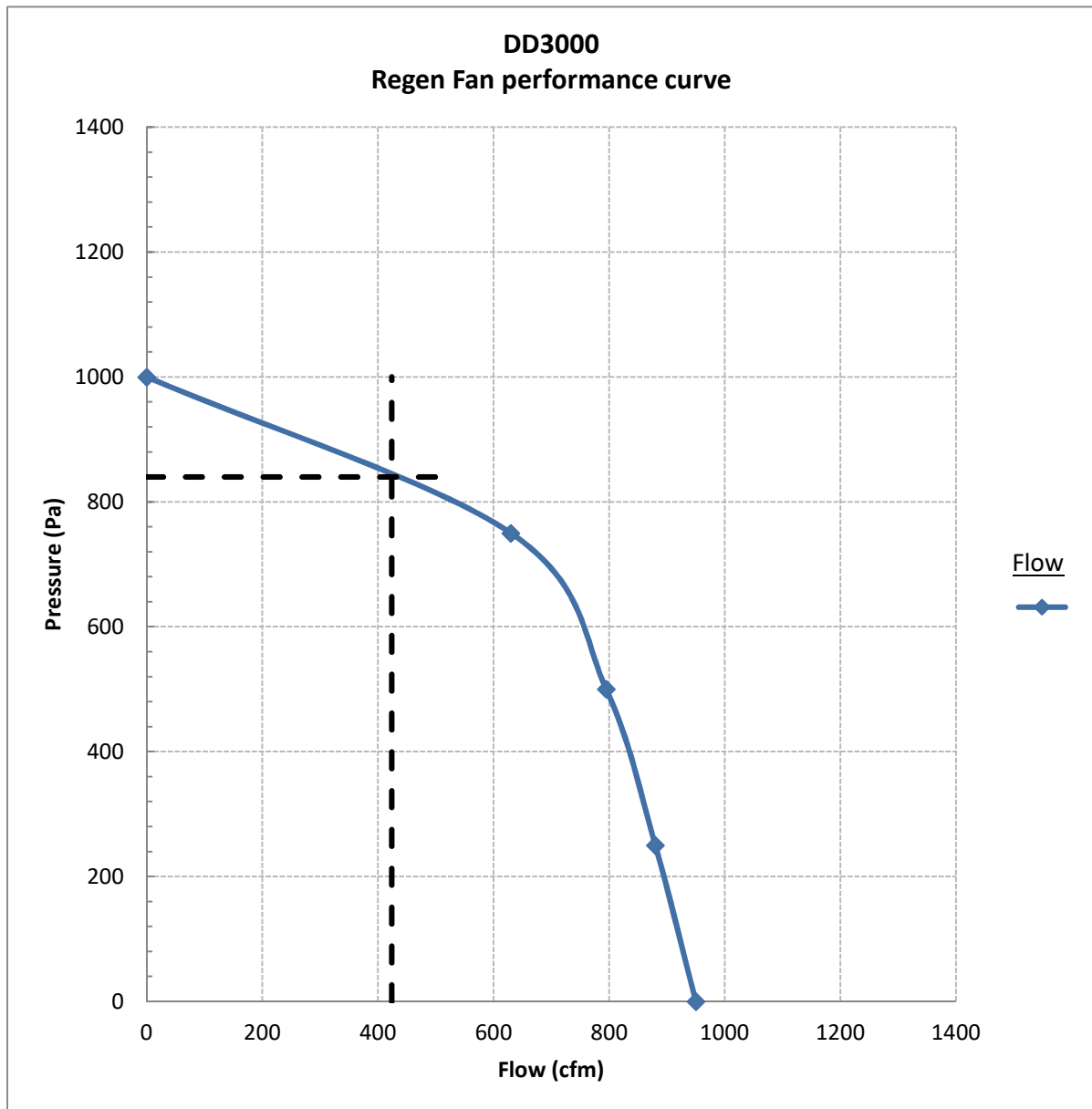

For example:

To achieve the required flow of 720m³/h (424cfm) the system resistance would need to be 840Pa – adjust the baffle to achieve this.

12.1 Electrical Component Details

Reference	EIPL Part No.	Description
ISO	3932329	Isolator – Main power switch
MAINS CB	3037738	Circuit Breaker – Bus bar feed 3ph 100A 440V Siemens 5TL1380-0
CB1	3037723	Circuit Breaker – Motors 3ph 10A Type C Siemens 5SY6310-7
CB2	3037735	Circuit Breaker – Heater bank 1 - 3ph 25A Type C Siemens 5SY7325-7
CB3	3037735	Circuit Breaker – Heater bank 2 - 3ph 25A Type C Siemens 5SY7325-7
CB4	3037737	Circuit Breaker – Transformer primary - 1ph 6A Type C Siemens 5SY6103-7
CB5	3037737	Circuit Breaker – Transformer primary - 1ph 6A Type C Siemens 5SY6103-7
CB6	3037737	Circuit Breaker – Transformer secondary - 1ph 6A Type C Siemens 5SY6103-7
RFC	3030312	Contactora - Regeneration fan – 3ph 17A 11kW Siemens 3RT2025-1AL20
DMC	3030312	Contactora - Drive motor – 3ph 17A 11kW Siemens 3RT2025-1AL20
PFC	3030312	Contactora - Process fan – 3ph 17A 11kW Siemens 3RT2025-1AL20
O/L1	3032610	Overload – Regeneration motor 7.0-10.0A Siemens 3RU2126-1-JB0 (Set 7.0A)
O/L2	3032613	Overload – Drive motor 0.32-1.25A Siemens 3RB3026-2NB0 (Set 0.9A)
O/L3	3032610	Overload – Process motor 7.0-10.0A Siemens 3RU2126-1-JB0 (Set 7.0A)
HB1C	3030315	Contactora - Heater bank 1 – 3ph 25A 11kW Siemens 3RT2026-1AL20
HB2C	3030315	Contactora - Heater bank 2 – 3ph 25A 11kW Siemens 3RT2026-1AL20
SSR1	3038308	Solid State Relay – Heater bank 2 - 3ph 25A 600V Crydom CTRC6025
TX1	3031173	Transformer 460-230V 420VA – Control circuit GRS Windings
RLA, RLB RLC, RLD	3030270	Control relays – 3A 240V Lirrd Typ LHH54P
	3477015	Relay base 14 pin 250Vac Omron PYF14A-N
RLE	3036193	Finder 40 series – 24Vdc
PSU-1	3036192	Power Supply 24dc out

		Lutze 722751
TD1	3036109	Time Delay Relay 24-240Vac/dc Tele Technik Enya series - E1ZMQ
TD2	3036109	Time Delay Relay 24-240Vac/dc Tele Technik Enya series - E1ZMQ
TEI	3030797	Hour counter 230V 60Hz Bauser 3800
OHP1 OHP1		Heater box internal overheat protector – set at 150°C Jumo EM-1 50 to 300°C
TCI		Heater box internal thermal cut in (fan run on) – set at 70°C Jumo EM-1 50 to 300°C
RTD1	3033392	RTD Sensor – TC Direct (514-210)
RTD2	3033393	RTD Sensor – TC Direct (514-201)
PS1	3033394	Proximity Switch - Rotation Sensor PNP Inductive sensor 30Vdc
SA1	3931735	Selector Switch – Auto/Manual Eaton M22-WRLK-W
	3930727	Selector Switch contact block – Auto/Manual 4A 230V (NO) Eaton M22-K10
	3931714	Selector Switch contact block – Auto/Manual 4A 230V (NC) Eaton M22-K01
Start	3931730	Push Button - Start switch Eaton M22-DL-G
	3930727	Start Switch contact block –4A 230Vac (NO) Eaton M22-K10
Stop	3931731	Push Button - Stop switch Eaton M22-DL-R
	3931714	Stop Switch contact block –4A 230Vac (NC) Eaton M22-K01
	3931708	Indicator – Various 230V ac Eaton M22-LED230-W
TC1	3031534	Temperature controller for regeneration air JUMO DICON Touch 4 x relay output
M1	3040298	Regeneration Motor – ACI VBW6-00460 3ph 1.4kW 2.2A
M2	3947019	Drive Motor – Mini-motor AC72TB5-SPL001 3ph 0.2kW 0.25A
M3	3947026	Process Motor – EBM K3G400-PI92-05 3ph 2.4kW 3.8A
M4 x 2	3947020	Cooling Fan – EBM Papst Type 4650N – 230V 19W
HB1-HB2	2060116	Regeneration Heater – 3ph 460V 2 x 12kW - Rica

backward curved, single inlet

with support bracket

ebm-papst Mulfingen GmbH & Co. KG

Bachmühle 2 · D-74673 Mulfingen

Phone +49 7938 81-0

Fax +49 7938 81-110

info1@de.ebmpapst.com

www.ebmpapst.com

Limited partnership · Headquarters Mulfingen

County court Stuttgart · HRA 590344

General partner Elektrobau Mulfingen GmbH · Headquarters Mulfingen

County court Stuttgart · HRB 590142

Nominal data

Type	K3G400-PI92-05	
Motor	M3G112-IA	
Phase		3~
Nominal voltage	VAC	400
Nominal voltage range	VAC	380 .. 480
Frequency	Hz	50/60
Type of data definition		ml
Speed (rpm)	min ⁻¹	2450
Power input	W	2500
Current draw	A	3.8
Min. ambient temperature	°C	-25
Max. ambient temperature	°C	40

ml = Max. load · me = Max. efficiency · fa = Running at free air · cs = Customer specs · cu = Customer unit
Subject to alterations

Data in accordance with ecodesign regulation EU 327/2011

		Actual	Request 2015
01 Overall efficiency η_{es}	%	70	55.5
02 Measurement category		A	
03 Efficiency category		Static	
04 Efficiency grade N		76.5	62
05 Variable speed drive		Yes	

Data definition with optimum efficiency.

The ErP data is determined using a motor-impeller combination in a standardised measurement configuration.

09 Power input P_{ed}	kW	2.39
09 Air flow q_v	m ³ /h	6600
09 Pressure increase p_{fs}	Pa	865
10 Speed (rpm) n	min ⁻¹	2480
11 Specific ratio*		1.01

* Specific ratio = $1 + p_{fs} / 100\,000\text{ Pa}$

LU-176408



backward curved, single inlet
with support bracket

Technical features

Mass	27 kg
Size	400 mm
Surface of rotor	Coated in black
Material of electronics housing	Die-cast aluminium
Material of impeller	Aluminium sheet
Material of mounting plate	Sheet steel, galvanised
Material of support bracket	Steel, coated in black
Number of blades	5
Direction of rotation	Clockwise, seen on rotor
Type of protection	IP54
Insulation class	"B"
Humidity (F)/environmental protection class (H)	H1
Max. permissible ambient motor temp. (transp./ storage)	+80 °C
Min. permissible ambient motor temp. (transp./storage)	-40 °C
Mounting position	Refer to product drawing
Condensation drainage holes	Rotor-side
Operation mode	S1
Motor bearing	Ball bearing
Technical features	<ul style="list-style-type: none"> - Output 10 VDC, max. 10 mA - Output 20 VDC, max. 50 mA - Output for slave 0-10 V - Operation and alarm display - Input for sensor 0-10 V or 4-20 mA - External 24 V input (programming) - External release input - Alarm relay - Integrated PID controller - Output limit - Motor current limit - PFC, passive - RS485 MODBUS RTU - Soft start - Control input 0-10 VDC / PWM - Control interface with SELV potential safely disconnected from the mains - Over-temperature protected electronics / motor - Line undervoltage / phase failure detection
EMC interference immunity	Acc. to EN 61000-6-2 (industrial environment)
EMC interference emission	Acc. to EN 61000-6-3 (household environment), except EN 61000-3-2 for professionally used devices with a total rated power greater than 1 kW
Touch current acc. IEC 60990 (measuring network Fig. 4, TN system)	<= 3.5 mA
Electrical leads	Via terminal box
Motor protection	Thermal overload protector (TOP) wired internally
Protection class	I (if protective earth is connected by customer)
Product conforming to standard	EN 61800-5-1; CE

K3G400-PI92-05

EC centrifugal module - RadiPac

backward curved, single inlet

with support bracket

Approval

C22.2 Nr.77 + CAN/CSA-E60730-1; EAC; UL 1004-7 + 60730



EC centrifugal module - RadiPac

backward curved, single inlet
with support bracket

Product drawing

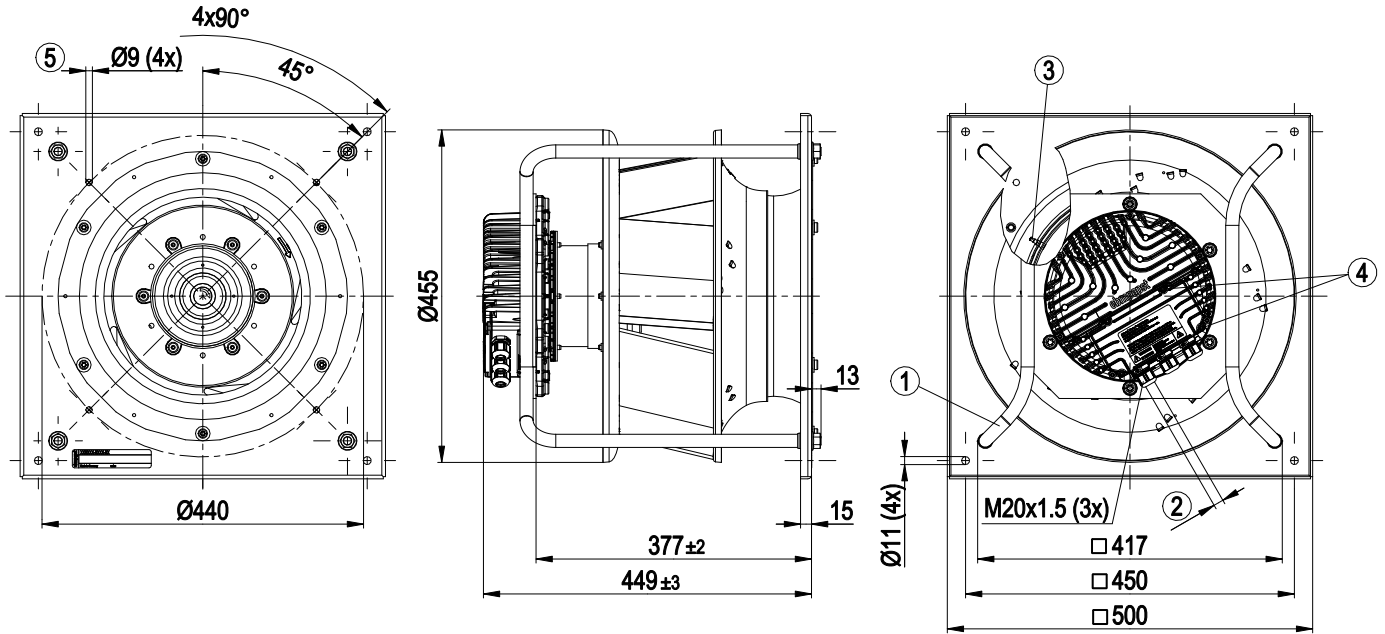

1	Installation position: Shaft horizontal (install the support struts only vertically as shown in the illustration!) or rotor on bottom; rotor on top on request
2	Cable diameter min. 4 mm, max. 10 mm, tightening torque 4±0.6 Nm
3	Inlet nozzle with pressure tap (k-factor: 188)
4	Tightening torque 3.5±0.5 Nm
5	Mounting holes for FlowGrid



EC centrifugal module - RadiPac

backward curved, single inlet

with support bracket

Connection screen

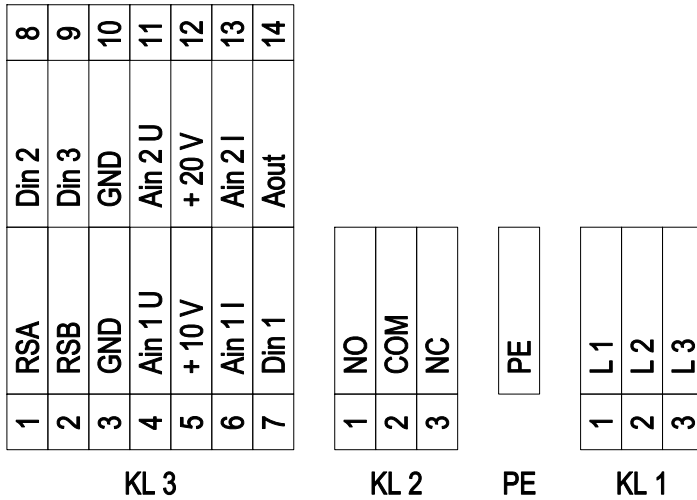

No.	Conn.	Designation	Function / assignment
KL 1	1	L1	Mains supply connection, supply voltage 3~380-480 VAC; 50/60 Hz
KL 1	2	L2	Mains supply connection, supply voltage 3~380-480 VAC; 50/60 Hz
KL 1	3	L3	Mains supply connection, supply voltage 3~380-480 VAC; 50/60 Hz
PE		PE	Earth connection, PE connection
KL 2	1	NO	Status relay, floating status contact; normally open; close with error
KL2	2	COM	Status relay; floating status contact; changeover contact; common connection; contact rating 250 VAC / max. 2 A (AC1) / min. 10 mA
KL2	3	NC	Status relay, floating status contact; break with error
KL 3	1	RSA	Bus connection RS-485, RSA, MODBUS RTU; SELV
KL 3	2	RSB	Bus connection RS-485, RSB, MODBUS RTU; SELV
KL 3	3 / 10	GND	Signal ground for control interface; SELV
KL 3	4	Ain1 U	Analogue input 1, set value: 0-10 V, Ri = 100 kΩ, parametrisable curve, only usable as alternative to input Ain1; SELV
KL 3	5	+ 10 V	Fixed voltage output 10 VDC, +10 V ±3%, max. 10 mA, short-circuit-proof, power supply for external devices (e.g. potentiometer), SELV
KL 3	6	Ain1 I	Analogue input 1, set value: 4-20 mA; Ri = 100 Ω, parametrisable curve, only usable as alternative to input Ain1 U; SELV
KL 3	7	Din1	Digital input 1: enabling of electronics, enabling: open pin or applied voltage 5-50 VDC disabling: bridge to GND or applied voltage <1 VDC reset function: triggers software reset after a level change to <1 VDC; SELV
KL 3	8	Din2	Digital input 2: parameter set switch 1/2, according to EEPROM setting, the valid/used parameter set can be selected via bus or via digital input DIN2. Parameter set 1: open pin or applied voltage 5-50 VDC Parameter set 2: bridge to GND or applied voltage <1 VDC; SELV
KL 3	9	Din3	Digital input 3: controller function of integrated controller, according to EEPROM setting, the controller function of the integrated controller is normally/inversely selectable per bus or per digital input normal: open pin or applied voltage 5-50 VDC inverse: bridge to GND or applied voltage <1 VDC; SELV
KL 3	11	Ain2 U	Analogue input 2, actual value: 0-10 V, Ri = 100 kΩ, parametrisable curve, only usable as alternative to input Ain2; SELV
KL 3	12	+ 20 V	Fixed voltage output 20 VDC, +20 V ±25/-10%, max. 50 mA, short-circuit-proof, power supply for external devices (e.g. sensors); SELV



EC centrifugal module - RadiPac

backward curved, single inlet

with support bracket

No.	Conn.	Designation	Function / assignment
KL 3	13	Ain2 I	Analogue input 2, actual value: 4-20 mA, $R_i = 100 \Omega$, parametrisable curve, only usable as alternative to input Ain2 U; SELV
KL 3	14	Aout	Analogue output 0-10 VDC, max. 5 mA, output of the current motor level control coefficient / motor speed parametrisable curve; SELV



Charts: Air flow 50 Hz

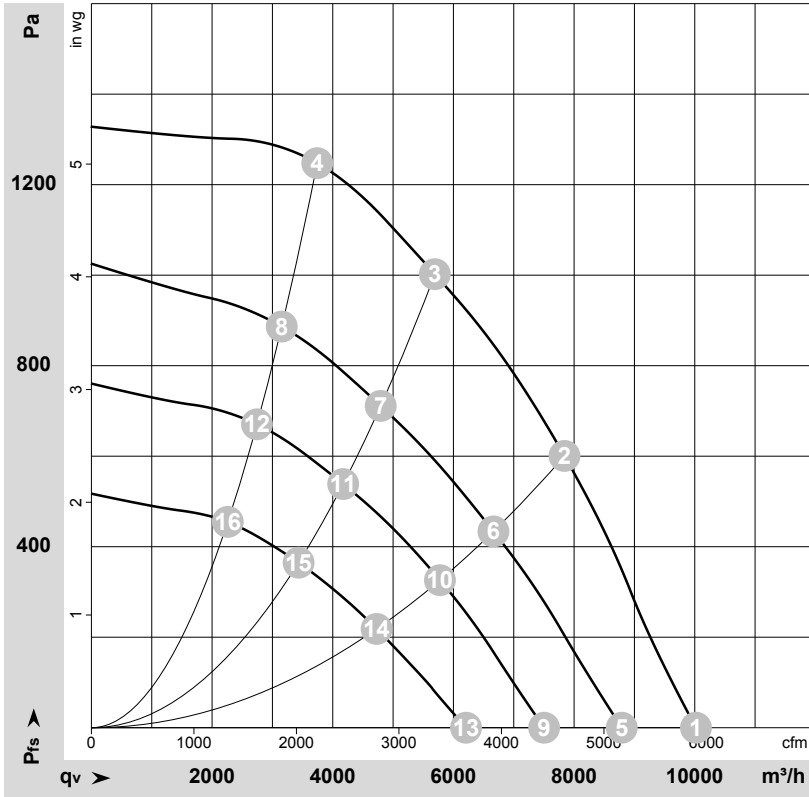

$\rho = 1.15 \text{ kg/m}^3 \pm 2 \%$

Measurement: LU-176408-1

Air performance measured as per ISO 5801 Installation category A. For detailed information on the measuring set-up, please contact ebmpapst. Suction-side noise levels: L_{wA} measured as per ISO 13347 / L_{pA} measured with 1m distance to fan axis. The values given are valid under the measuring conditions mentioned above and may vary according to the actual installation situation. With any deviation from the standard set-up, the specific values have to be checked and reviewed with the unit installed.

Measured values

	Conn.	U	f	n	P _{ed}	I	LpA _{in}	LwA _{in}	LwA _{out}	q _v	P _{fs}	q _v	P _{fs}
		V	Hz	min ⁻¹	W	A	dB(A)	dB(A)	dB(A)	m ³ /h	Pa	cfm	in. wg
1	Y	400	50	2450	1323	2.07	89	96	96	10020	0	5900	0.00
2	Y	400	50	2450	2210	3.38	77	85	88	7840	600	4615	2.41
3	Y	400	50	2450	2500	3.80	74	82	86	5690	1000	3350	4.01
4	Y	400	50	2450	2336	3.57	78	86	90	3745	1250	2205	5.02
5	Y	400	50	2180	921	1.50	84	91	92	8790	0	5175	0.00
6	Y	400	50	2100	1376	2.15	72	80	84	6665	434	3920	1.74
7	Y	400	50	2080	1479	2.30	70	77	83	4795	712	2820	2.86
8	Y	400	50	2090	1420	2.22	74	81	85	3155	887	1855	3.56
9	Y	400	50	1875	626	1.10	80	87	88	7505	0	4415	0.00
10	Y	400	50	1825	923	1.50	69	77	81	5775	326	3400	1.31
11	Y	400	50	1810	994	1.60	66	74	80	4175	539	2455	2.16
12	Y	400	50	1815	955	1.55	69	77	82	2745	671	1615	2.69
13	Y	400	50	1545	377	0.73	74	83	85	6210	0	3655	0.00
14	Y	400	50	1500	545	1.00	64	72	77	4725	220	2780	0.88
15	Y	400	50	1490	585	1.05	62	69	76	3435	365	2020	1.47
16	Y	400	50	1495	566	1.03	64	72	78	2260	455	1330	1.83

Conn. = Connection · U = Supply voltage · f = Frequency · n = Speed (rpm) · P_{ed} = Power input · I = Current draw · LpA_{in} = Sound pressure level inlet side · LwA_{in} = Sound power level inlet side
LwA_{out} = Sound power level outlet side · q_v = Air flow · P_{fs} = Pressure increase



Centrifugal Fan VBW6

Single Inlet Centrifugal Fan

General Characteristics:



[Please note - image above may not be representative of the unit supplied]

Motor type:	Squirrel cage induction motor IP55 as std, IP65 available
Nominal supply:	220/240V or 115V 1Ph 50/60Hz 380/420VY / 220/240VD 3Ph 50Hz 440/480VY / 250/280VD 3Ph 60Hz
Options:	Inlet & discharge guards, Inlet filters, Spigots
Materials:	Fancase: Cast aluminium LM6 Impellers: Galvanised sheet steel
Finishes:	Unpainted/Stove enamel (black) as std
Mounting options:	Motor feet or Pedestal
Noise levels:	86.5dB(A) Free Air, 1M
Weight:	14Kgs / 31Lbs
Motor Variations:	ATEX, CE, CSA, UL available

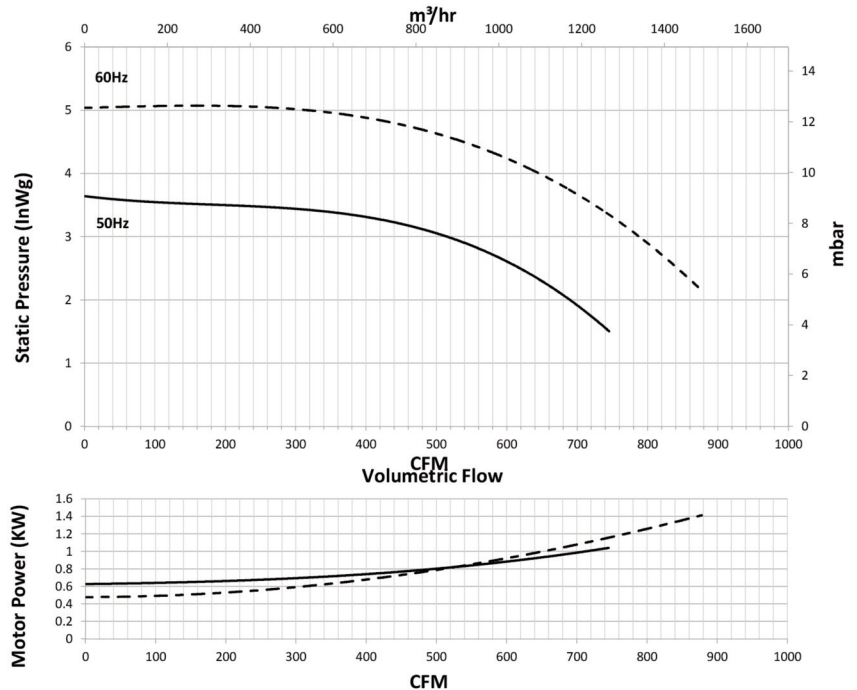

Outline dimensions:

[Note: motor shown is for 50Hz performance.
Motor dimensions for 60Hz operation may vary]

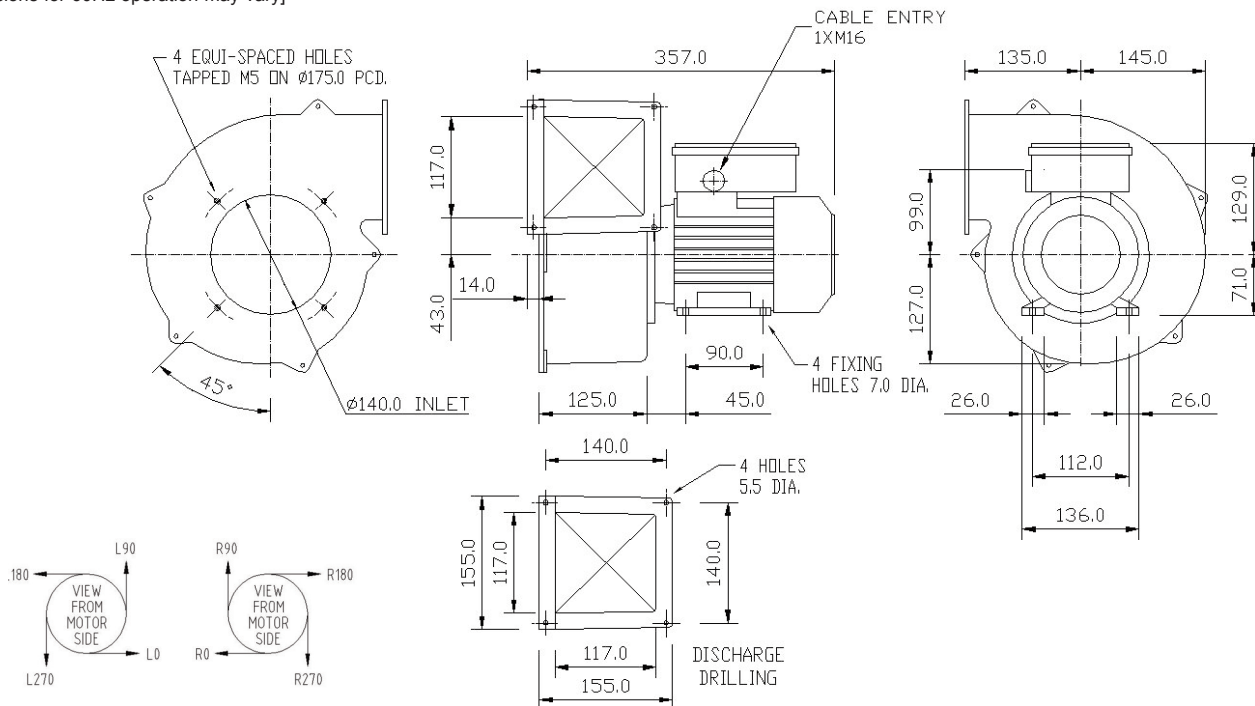

Please note (1) - all drawings measurements are in millimeters (mm)
Please note (2) - above technical specifications are subject to change

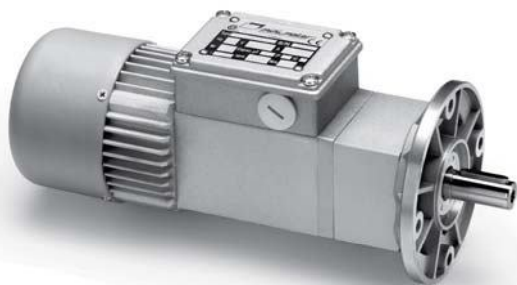

IT MOTORIDUTTORE COASSIALE AD INGRANAGGI CON RIDUTTORE EPICICLOIDALE

MOTORE: asincrono monofase o trifase a 2 o 4 poli, in forma chiusa con ventilazione esterna. Protettore termico di sicurezza nel tipo monofase. Avvolgimento classe F. Protezione IP65 secondo norme CEI EN 60529.

RIDUTTORE: primo stadio con carcassa in alluminio pressofuso, secondo stadio in acciaio. Ingranaggi cementati e temperati con relativi alberi ruotanti su cuscinetti a rulli. Lubrificazione con olio speciale a lunga durata. Anelli di tenuta in gomma speciale per alte temperature. I rapporti di riduzione disponibili (i) sono 15, da 37 a 2209,5. Coppia nominale 23,5 Nm. Versione B3 o B5.

EN COAXIAL GEARED MOTOR WITH PLANETARY REDUCTION GEAR

MOTOR: asynchronous single or three phase with 2 or 4 poles, totally enclosed with external ventilation. Thermal safety cutout on single phase model. Class F. IP65 protection according to CEI EN 60529.

GEAR UNIT: first stage with die-cast aluminium case, second stage in steel. Case-hardened and hardened gear pairs with shafts rotating on roller bearings. Lubrication with long life oil. Sealing rings made in special rubber for high temperatures. 15 gear ratios (i) available, from 37 to 2209.5. Rated torque 23.5 Nm.

Version B3 or B5.

DE KOAXIALER GETRIEBEMOTOR MIT STIRNRADSATZ UND PLANETENGETRIEBE

MOTOR: Einphasen- oder Drehstrom- Asynchronmotor, zwei- oder vierpolig, in geschlossener Ausführung mit externer Belüftung. Thermoschutzschalter bei der einphasigen Ausführung. Isolationsklasse F. Schutzart IP65 gem. CEI EN 60529.

UNTERSETZUNGSGETRIEBE: Erste Stufe mit Gehäuse aus Alu-Druckguss, zweite Stufe aus Stahl. Aufgekohlte und gehärtete Stirnräder mit in Rollenlagern gelagerten Wellen. Schmierung mit Spezialöl mit Langzeitwirkung.

Dichtungsringe aus hitzebeständigem Gummi. Es gibt 15 Untersetzungsverhältnisse (i), von 37 bis 2209,5. Nenn Drehmoment 23,5 Nm. Bauformen B3 oder B5.

FR MOTOREDUCTEUR COAXIAL A ENGRENAGES AVEC REDUCTEUR EPICYCLOIDAL

MOTEUR: asynchrone monophasé ou triphasé à 2 ou 4 pôles, fermé avec ventilation extérieure. Protection thermique de sécurité dans le modèle monophasé. Enroulement classe F. Protection IP 65, conformément aux normes CEI EN 60529.

REDUCTEUR: premier étage avec carcasse en aluminium moulé sous pression, deuxième étage en acier. Engrenages cimentés et trempés, arbres sur roulements à aiguilles. Lubrification par huile spéciale longue durée. Joints d'étanchéité en élastomère spécial pour hautes températures. 15 rapports de réduction (i), de 37 à 2209,5. Couple nominal 23,5 Nm. Version B3 ou B5.

ES MOTORREDUCTOR COAXIAL DE ENGRANAJES CON REDUCTOR EPICICLOIDAL

MOTOR: asíncrono monofásico o trifásico de 2 ó 4 polos, en forma cerrada con ventilación externa. Protector térmico de seguridad en el tipo monofásico. Aislamiento clase F. Protección IP 65 según normas CEI EN 60529.

REDUCTOR: Primera etapa con carcasa de aluminio inyectado a presión, segunda etapa de acero. Engranajes templados y endurecidos con correspondientes ejes que giran sobre cojinetes de rodillos. Lubricación con aceite especial de larga duración. Retenes para la estanqueidad de goma especial para altas temperaturas. Las relaciones de reducción disponibles (i) son 15, de 37 a 2209,5. Par nominal 23,5 Nm. Versión B3 ó B5.

IT N.B. Per una corretta scelta del motoriduttore si consiglia di attenersi alle tabelle riportate a pagina 140-141. Per i giri motore a carico riferirsi alla serie AM pag. 15. A richiesta è possibile fornire il motore con freno elettromagnetico alimentato a 230 Vac, contraddistinto con lettera KA (ACEKA) o a 24Vdc contraddistinto con lettera KB (ACEKB), vedi caratteristiche a pag. 142.

EN N.B. For the correct choice of the gearmotor, please refer to the tables on page 140-141. Refer to AM series page 15 for motor revs under load. On request, the motor can be supplied with electromagnetic brake at 230 Vac, marked with letter KA (ACEKA), or 24 Vdc, marked with letter KB (ACEKB), see specifications on page 142.

DE ANMERKUNG. Für die richtige Wahl des Getriebemotors wird empfohlen, die Tabellen auf Seite 140-141 zu beachten. Für die Motordrehzahl unter Belastung vgl. Serie AM auf Seite 15. Auf Wunsch ist der Motor mit elektromagnetischer Scheibenbremse, 230 Vac, gekennzeichnet mit dem Buchstaben KA (ACEKA), oder 24 Vdc, gekennzeichnet mit dem Buchstaben KB (ACEKB), erhältlich, Beschreibung s. Seite 142.

FR N.B. Pour un choix correct du motoréducteur il est conseillé de consulter les tableaux techniques, page 140-141. Pour les tours du moteur chargé consulter la série AM, page 15. Sur demande, le moteur peut être livré équipé de frein électromagnétique, alimenté à 230 Vac, avec la désignation KA (ACEKA), ou 24 Vdc, avec la désignation KB (ACEKB), voir caractéristiques, page 142.

ES N.B. Para una selección correcta del motorreductor se aconseja ajustarse a las tablas presentadas en la página 140-141. Para las revoluciones motor bajo carga hágase referencia a la serie AM pag. 15. A petición es posible proporcionar el motor con freno electromagnético alimentado con 230 Vac, que se distingue por la letra KA (ACEKA), ó con 24 Vdc, que se distingue por las letras KB (ACEKB), ver características en la pag. 142.



Tipo Type Typ Type Tipo	Rapporto Ratio Übersetzungs- verhältnis Rapport Relación	Potenza resa Delivered power Abgegebene Leistung Puissance développée Potencia entregada	Giri entrata a vuoto Input r.p.m. no-load Eingangsdrehzahl unbelastet Tours en entrée à vide Revoluciones entrada sin carga	Giri uscita a vuoto Output r.p.m. no-load Ausgangsdrehzahl unbelastet Tours à la sortie à vide Revoluciones salida sin carga	Coppia nominale Rated torque Nenn Drehmoment Couple nominal Par nominal	Tensione Voltage Spannung Voltage Tensión	Corrente Current Strom Courant Intensidad	Condensatore Capacitor Kondensator Condensateur Condensador
	i	W	rpm	rpm	Nm	Vac - 50 Hz	A	µF
ACE 66	37	27	2800	75	2,9	230	0,34	2,5
ACE 100P	37	35	2800	75	3,8	230	0,41	3,15
ACE 160P2	37	60	2800	75	6,5	230	0,54	4
ACE 44	37	11	1400	37,5	2,5	230	0,26	3,15
ACE 80P	37	15	1400	37,5	3,5	230	0,33	4
ACE 110P2	37	19	1400	37,5	4,4	230	0,41	5
ACE 72T	37	19	2800	75	2	230Δ 400Υ	0,22Δ 0,13Υ	-
ACE 244PT	37	49	2800	75	5,3	230Δ 400Υ	0,52Δ 0,30Υ	-
ACE 320P2T	37	74	2800	75	7,9	230Δ 400Υ	0,62Δ 0,36Υ	-
ACE 66T	37	10	1400	37,5	2,3	230Δ 400Υ	0,19Δ 0,11Υ	-
ACE 110PT	37	14	1400	37,5	3,2	230Δ 400Υ	0,25Δ 0,14Υ	-
ACE 145P2T	37	18	1400	37,5	4,1	230Δ 400Υ	0,32Δ 0,18Υ	-
ACE 66	50,8	27	2800	55	4	230	0,34	2,5
ACE 100P	50,8	35	2800	55	5,2	230	0,41	3,15
ACE 160P2	50,8	60	2800	55	8,9	230	0,54	4
ACE 44	50,8	11	1400	27,5	3,6	230	0,26	3,15
ACE 80P	50,8	15	1400	27,5	4,8	230	0,33	4
ACE 110P2	50,8	19	1400	27,5	6,1	230	0,41	5
ACE 72T	50,8	19	2800	55	2,8	230Δ 400Υ	0,22Δ 0,13Υ	-
ACE 244PT	50,8	49	2800	55	7,3	230Δ 400Υ	0,52Δ 0,30Υ	-
ACE 320P2T	50,8	74	2800	55	10,9	230Δ 400Υ	0,62Δ 0,36Υ	-
ACE 66T	50,8	10	1400	27,5	3,2	230Δ 400Υ	0,19Δ 0,11Υ	-
ACE 110PT	50,8	14	1400	27,5	4,4	230Δ 400Υ	0,25Δ 0,14Υ	-
ACE 145P2T	50,8	18	1400	27,5	5,6	230Δ 400Υ	0,32Δ 0,18Υ	-
ACE 66	66,6	27	2800	42	5,3	230	0,34	2,5
ACE 100P	66,6	35	2800	42	6,9	230	0,41	3,15
ACE 160P2	66,6	60	2800	42	11,7	230	0,54	4
ACE 44	66,6	11	1400	21	4,7	230	0,26	3,15
ACE 80P	66,6	15	1400	21	6,3	230	0,33	4
ACE 110P2	66,6	19	1400	21	7,9	230	0,41	5
ACE 72T	66,6	19	2800	42	3,7	230Δ 400Υ	0,22Δ 0,13Υ	-
ACE 244PT	66,6	49	2800	42	9,5	230Δ 400Υ	0,52Δ 0,30Υ	-
ACE 320P2T	66,6	74	2800	42	14,3	230Δ 400Υ	0,62Δ 0,36Υ	-
ACE 66T	66,6	10	1400	21	4,2	230Δ 400Υ	0,19Δ 0,11Υ	-
ACE 110PT	66,6	14	1400	21	5,8	230Δ 400Υ	0,25Δ 0,14Υ	-
ACE 145P2T	66,6	18	1400	21	7,4	230Δ 400Υ	0,32Δ 0,18Υ	-
ACE 66	88,8	27	2800	31,5	7,1	230	0,34	2,5
ACE 100P	88,8	35	2800	31,5	9,2	230	0,41	3,15
ACE 160P2	88,8	60	2800	31,5	15,6	230	0,54	4
ACE 44	88,8	11	1400	15,7	6,3	230	0,26	3,15
ACE 80P	88,8	15	1400	15,7	8,5	230	0,33	4
ACE 110P2	88,8	19	1400	15,7	10,6	230	0,41	5
ACE 72T	88,8	19	2800	31,5	4,9	230Δ 400Υ	0,22Δ 0,13Υ	-
ACE 244PT	88,8	49	2800	31,5	12,7	230Δ 400Υ	0,52Δ 0,30Υ	-
ACE 320P2T	88,8	74	2800	31,5	19,1	230Δ 400Υ	0,62Δ 0,36Υ	-
ACE 66T	88,8	10	1400	15,7	5,6	230Δ 400Υ	0,19Δ 0,11Υ	-
ACE 110PT	88,8	14	1400	15,7	7,8	230Δ 400Υ	0,25Δ 0,14Υ	-
ACE 145P2T	88,8	18	1400	15,7	9,9	230Δ 400Υ	0,32Δ 0,18Υ	-



ACE

Tipo Type Typ Type Tipo	Rapporto Ratio Übersetzungs- verhältnis Rapport Relación	Potenza resa Delivered power Abgegebene Leistung Puissance développée Potencia entregada	Giri entrata a vuoto Input r.p.m. no-load Eingangsdrehzahl unbelastet Tours en entrée à vide Revoluciones entrada sin carga	Giri uscita a vuoto Output r.p.m. no-load Ausgangsdrehzahl unbelastet Tours à la sortie à vide Revoluciones salida sin carga	Coppia nominale Rated torque Nenn Drehmoment Couple nominal Par nominal	Tensione Voltage Spannung Voltage Tensión	Corrente Current Strom Courant Intensidad	Condensatore Capacitor Kondensator Condensateur Condensador
	i	W	rpm	rpm	Nm	Vac - 50 Hz	A	µF
ACE 66	122,1	27	2800	22,9	9,7	230	0,34	2,5
ACE 100P	122,1	35	2800	22,9	12,7	230	0,41	3,15
ACE 160P2	122,1	60	2800	22,9	21,4	230	0,54	4
ACE 44	122,1	11	1400	11,4	8,7	230	0,26	3,15
ACE 80P	122,1	15	1400	11,4	11,7	230	0,33	4
ACE 110P2	122,1	19	1400	11,4	14,6	230	0,41	5
ACE 72T	122,1	19	2800	22,9	6,8	230△400Υ	0,22△0,13Υ	-
ACE 244PT	122,1	49	2800	22,9	17,5	230△400Υ	0,52△0,30Υ	-
ACE 320P2T	122,1	74	2800	22,9	*23,5	230△400Υ	0,62△0,36Υ	-
ACE 66T	122,1	10	1400	11,4	7,8	230△400Υ	0,19△0,11Υ	-
ACE 110PT	122,1	14	1400	11,4	10,7	230△400Υ	0,25△0,14Υ	-
ACE 145P2T	122,1	18	1400	11,4	13,6	230△400Υ	0,32△0,18Υ	-
ACE 66	159,8	27	2800	17,5	12,7	230	0,34	2,5
ACE 100P	159,8	35	2800	17,5	16,8	230	0,41	3,15
ACE 160P2	159,8	60	2800	17,5	*23,5	230	0,54	4
ACE 44	159,8	11	1400	8,7	11,5	230	0,26	3,15
ACE 80P	159,8	15	1400	8,7	15,3	230	0,33	4
ACE 110P2	159,8	19	1400	8,7	19,1	230	0,41	5
ACE 72T	159,8	19	2800	17,5	8,9	230△400Υ	0,22△0,13Υ	-
ACE 244PT	159,8	49	2800	17,5	23	230△400Υ	0,52△0,30Υ	-
ACE 66T	159,8	10	1400	8,7	10,2	230△400Υ	0,19△0,11Υ	-
ACE 110PT	159,8	14	1400	8,7	14	230△400Υ	0,25△0,14Υ	-
ACE 145P2T	159,8	18	1400	8,7	17,9	230△400Υ	0,32△0,18Υ	-
ACE 66	213	27	2800	13	17	230	0,34	2,5
ACE 100P	213	35	2800	13	22,1	230	0,41	3,15
ACE 44	213	11	1400	6,5	15,3	230	0,26	3,15
ACE 80P	213	15	1400	6,5	20,4	230	0,33	4
ACE 72T	213	19	2800	13	11,9	230△400Υ	0,22△0,13Υ	-
ACE 244PT	213	49	2800	13	*23,5	230△400Υ	0,52△0,30Υ	-
ACE 66T	213	10	1400	6,5	13,6	230△400Υ	0,19△0,11Υ	-
ACE 110PT	213	14	1400	6,5	18,7	230△400Υ	0,25△0,14Υ	-
ACE 145P2T	213	18	1400	6,5	*23,5	230△400Υ	0,32△0,18Υ	-
ACE 66	293	27	2800	9,5	23,4	230	0,34	2,5
ACE 44	293	11	1400	4,7	21,1	230	0,26	3,15
ACE 72T	293	19	2800	9,5	16,4	230△400Υ	0,22△0,13Υ	-
ACE 66T	293	10	1400	4,7	18,7	230△400Υ	0,19△0,11Υ	-
ACE 66	383,6	27	2800	7,2	*23,5	230	0,34	2,5
ACE 44	383,6	11	1400	3,6	*23,5	230	0,26	3,15
ACE 72T	383,6	19	2800	7,2	21,4	230△400Υ	0,22△0,13Υ	-
ACE 66T	383,6	10	1400	3,6	*23,5	230△400Υ	0,19△0,11Υ	-
ACE 66	511,4	27	2800	5,4	*23,5	230	0,34	2,5
ACE 44	511,4	11	1400	2,7	*23,5	230	0,26	3,15
ACE 72T	511,4	19	2800	5,4	*23,5	230△400Υ	0,22△0,13Υ	-
ACE 66T	511,4	10	1400	2,7	*23,5	230△400Υ	0,19△0,11Υ	-
ACE 66	703	27	2800	3,9	*23,5	230	0,34	2,5
ACE 44	703	11	1400	1,9	*23,5	230	0,26	3,15
ACE 72T	703	19	2800	3,9	*23,5	230△400Υ	0,22△0,13Υ	-
ACE 66T	703	10	1400	1,9	*23,5	230△400Υ	0,19△0,11Υ	-

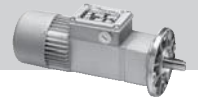

Tipo Type Typ Type Tipo	Rapporto Ratio Übersetzungs- verhältnis Rapport Relación	Potenza resa Delivered power Abgegebene Leistung Puissance développée Potencia entregada	Giri entrata a vuoto Input r.p.m. no-load Eingangsdrehzahl unbelastet Tours en entrée à vide Revoluciones entrada sin carga	Giri uscita a vuoto Output r.p.m. no-load Ausgangsdrehzahl unbelastet Tours à la sortie à vide Revoluciones salida sin carga	Coppia nominale Rated torque Nenn Drehmoment Couple nominal Par nominal	Tensione Voltage Spannung Voltage Tensión	Corrente Current Strom Courant Intensidad	Condensatore Capacitor Kondensator Condensateur Condensador
	i	W	rpm	rpm	Nm	Vac - 50 Hz	A	µF
ACE 66	920,5	27	2800	3	*23,5	230	0,34	2,5
ACE 44	920,5	11	1400	1,5	*23,5	230	0,26	3,15
ACE 72T	920,5	19	2800	3	*23,5	230△400Υ	0,22△0,13Υ	-
ACE 66T	920,5	10	1400	1,5	*23,5	230△400Υ	0,19△0,11Υ	-
ACE 66	1227,5	27	2800	2,2	*23,5	230	0,34	2,5
ACE 44	1227,5	11	1400	1,1	*23,5	230	0,26	3,15
ACE 72T	1227,5	19	2800	2,2	*23,5	230△400Υ	0,22△0,13Υ	-
ACE 66T	1227,5	10	1400	1,1	*23,5	230△400Υ	0,19△0,11Υ	-
ACE 66	1687,5	27	2800	1,6	*23,5	230	0,34	2,5
ACE 44	1687,5	11	1400	0,8	*23,5	230	0,26	3,15
ACE 72T	1687,5	19	2800	1,6	*23,5	230△400Υ	0,22△0,13Υ	-
ACE 66T	1687,5	10	1400	0,8	*23,5	230△400Υ	0,19△0,11Υ	-
ACE 66	2209,5	27	2800	1,2	*23,5	230	0,34	2,5
ACE 44	2209,5	11	1400	0,6	*23,5	230	0,26	3,15
ACE 72T	2209,5	19	2800	1,2	*23,5	230△400Υ	0,22△0,13Υ	-
ACE 66T	2209,5	10	1400	0,6	*23,5	230△400Υ	0,19△0,11Υ	-

- (IT)** (*) - I valori relativi alla coppia contrassegnati con l'asterisco non devono assolutamente essere superati, in quanto, con i rapporti elevati, la potenza motore è notevolmente superiore alla portata del riduttore.
- (EN)** (*) - Under no circumstances should the torque values marked with an asterisk be exceeded, as for the higher gear ratios the motor power is considerably higher than the capacity of the gear unit.
- (DE)** (*) - Die mit einem Stern bezeichneten Drehmomente dürfen keinesfalls überschritten werden, da bei hohen Übersetzungen die Motorleistung viel höher als die zulässige Belastung des Getriebes ist.
- (FR)** (*) - Les valeurs correspondants au couple, marqués par un astérisque, ne doivent absolument pas être dépassés car, en cas des rapports élevés, la puissance du moteur est considérablement supérieure à la capacité du réducteur.
- (ES)** (*) - Los valores referentes al par marcados con el asterisco, no se deben en absoluto superar, ya que, con las altas relaciones, la potencia del motor es notablemente mayor que la capacidad del reductor.

ACE

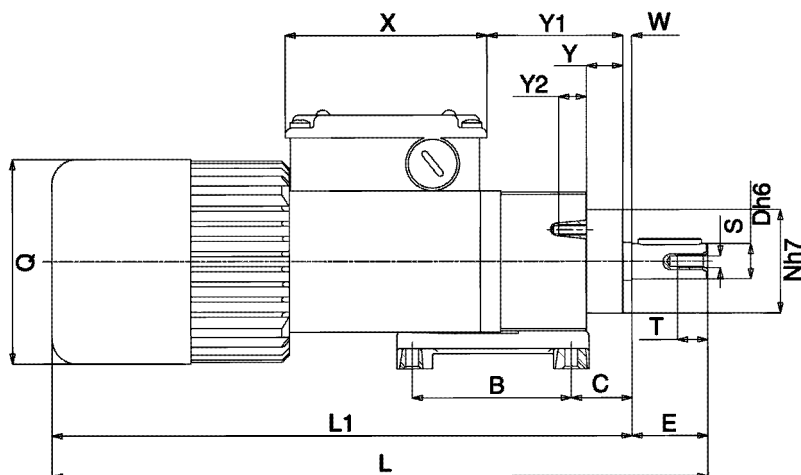
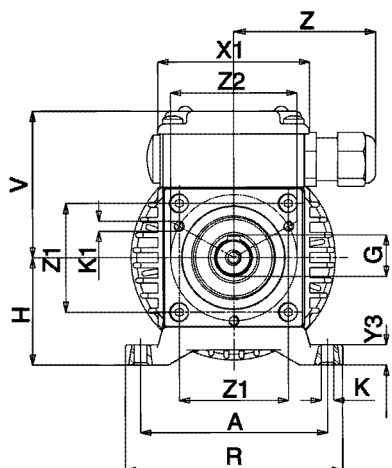

E

	74	63	24	14	30	5	16	43	5,5	M4	256	226	41	81	86	M5	12	60	80	60	14,5	55	11	8	3,5	56	43	50	2,645
ACE...	74	63	24	14	30	5	16	43	5,5	M4	256	226	41	81	86	M5	12	60	80	60	14,5	55	11	8	3,5	56	43	50	2,645
ACE...P	74	63	24	14	30	5	16	43	5,5	M4	271	241	41	81	86	M5	12	60	80	60	14,5	55	11	8	3,5	56	43	50	2,910

Peso
weight
oids
Peso
kg

20

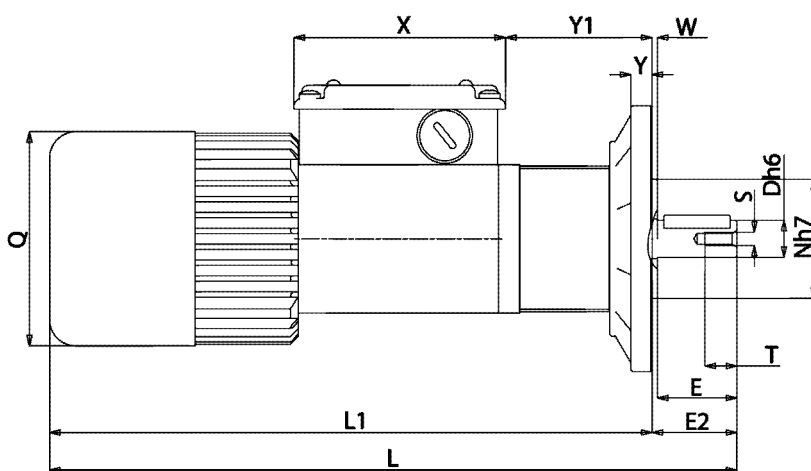
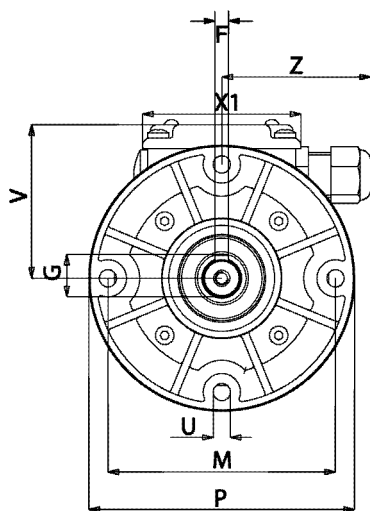

I

type Tipo																													Peso kg
ACE...	14	30	32	5	16	256	224	86	45	100	81	M5	12	6,5	60	80	60	8	57	2	56							2,675	
ACE...P	14	30	32	5	16	271	239	86	45	100	81	M5	12	6,5	60	80	60	8	57	2	56							2,940	
ACE...P2	14	30	32	5	16	291	259	86	45	100	81	M5	12	6,5	60	80	60	8	57	2	56							3,350	

Peso
weight
oids
Peso
kg

(IT) Nella versione autofrenante aggiungere alla sigla del tipo la lettera KA o KB. Le quote L, L1 aumentano di 27 mm.

(EN) For the self-braking version, add the letter KA or KB to the type designation. Dimensions L, L1 increase by 27 mm.

(DE) In der Ausführung als Bremsmotor ist der Typen-Kurzbezeichnung der Buchstabe KA oder KB beizufügen. Die Masse L, L1 werden um 27 mm erhöht.

(FR) Pour la version avec frein ajouter au sigle du type les lettres KA ou KB. Les dimensions L, L1 augmentent de 27 mm.

(ES) En la versión freno, añadir las letras KA ó KB a la sigla del tipo. Las cotas L, L1 aumentan de 27 mm.

JUMO DICON touch

Two-channel process and program controller with paperless recorder and touchscreen

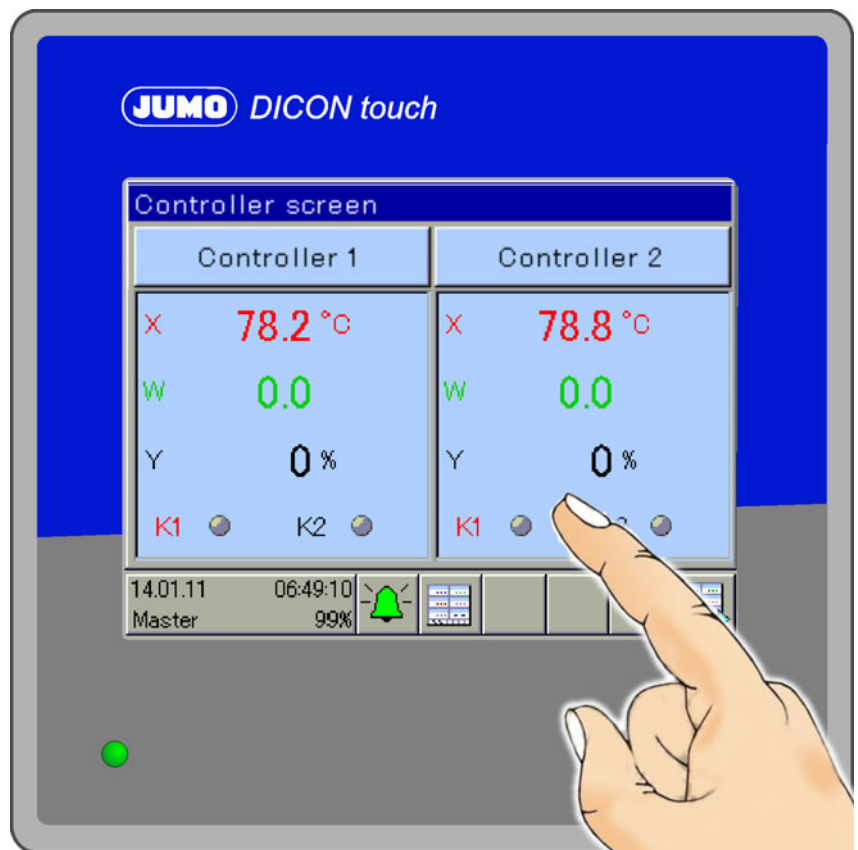

Quick start guide



1	Introduction	7
1.1	Safety information	7
1.1.1	Warning symbols	7
1.1.2	Note signs	7
1.1.3	Representation	8
1.2	Description	9
1.3	Block diagram	10
2	Identifying the device version	11
2.1	Order details	11
2.2	Scope of delivery	13
2.3	General accessories	13
2.4	Accessories	14
2.5	Nameplate	15
3	Mounting	17
3.1	Mounting site and climatic conditions	17
3.1.1	Environmental influences	17
3.1.2	Electrical data	17
3.1.3	Case	17
3.2	Dimensions	18
3.3	Close mounting	19
3.4	Insertion in panel cut-out	19
3.5	Care and treatment of the front cover	19
4	Electrical connection	21
4.1	Installation notes	21
4.1.1	Cables, shielding, and grounding	21
4.1.2	Electrical safety	21
4.1.3	Intended use, misuse	22
4.2	Galvanic isolation	22
4.3	Connection diagram	23
4.3.1	Connection elements	23
4.3.2	Analog inputs	24
4.3.3	Probes for the operating medium air	25
4.3.4	Probes for the operating medium water and oil	26
4.3.5	Probes for the operating medium water, oil and air	26
4.3.6	Analog outputs	27
4.3.7	Digital inputs	27
4.3.8	Digital outputs	27
4.3.9	Digital outputs	29
4.3.10	Voltage supply (according to nameplate)	30
4.3.11	Interfaces	31

5	Operation	33
5.1	Display and operating concept	33
5.2	Device menu	34
5.3	Alarm and event list	34
5.4	Function buttons, history and channel changeover	34
5.5	Images in the operating loop	35
5.5.1	Controller screen 1, Controller screen 2 and Controller overview	35
5.5.2	Program controller	37
5.5.3	General screen 1.2	38
5.5.4	Recording image	38
5.5.5	Process screen	39
6	Login	41
6.1	Logging on	42
6.2	Logging out	42
6.3	Changing the password	42
7	Program administration	43
7.1	Enter program curves	43
7.1.1	On the device	43
7.1.2	About the setup program	44
7.1.3	Section run time	45
7.1.4	Setpoint values 1 and 2	45
7.1.5	Control contacts	45
7.1.6	Tolerance band	46
7.1.7	Number of repetitions	46
7.1.8	Start section	46
7.1.9	Parameter block	46
8	Parameterization	47
8.1	Date and time	47
8.2	Daylight saving time	47
8.3	Controller/parameter blocks	48
8.4	Setpoint values	52
8.4.1	Entered on the device	53
8.4.2	Entered using the setup program	53
9	Configuration	55
9.1	Analog selector	55
9.2	Digital selector	56
9.3	General information	60
9.4	Example basic settings	60

9.5	Example to set Analog inputs IN8, IN9, IN10, IN11	60
10	Special functions	61
10.1	Calibrating the touchscreen	61
11	Error and alarm messages	63
11.1	Error messages in float values and on the display	63
11.2	Display of error messages for binary values	63

1.1 Safety information

General information

This manual contains information that must be observed in the interest of your own safety and to avoid damage to assets. This information is supported by symbols which are used in this manual as indicated.

Please read this manual before commissioning the device. Keep the manual in a place accessible to all users at all times.

If difficulties occur during commissioning please refrain from carrying out any manipulations that could jeopardize your warranty rights.

1.1.1 Warning symbols



DANGER!

This symbol indicates that **personal injury caused by electrical shock** may occur if the respective precautionary measures are not carried out.



WARNING!

This symbol in connection with the signal word indicates that personal injury may occur if the respective precautionary measures are not carried out.



CAUTION!

This symbol in connection with the signal word indicates that **damage to assets or data loss** will occur if the respective precautionary measures are not taken.



CAUTION!

This symbol indicates that **components could be destroyed** by electrostatic discharge (ESD = Electro Static Discharge) if the respective cautionary measures are not taken. Only use the ESD packages intended for this purpose to return device inserts, assembly groups, or assembly components.



READ DOCUMENTATION!

This symbol – placed on the device – indicates that the associated **device documentation has to be observed**. This is necessary to recognize the kind of the potential hazards as well as the measures to avoid them.

1.1.2 Note signs



NOTE!

This symbol refers to **important information** about the product, its handling, or additional use.



REFERENCE!

This symbol refers to **further information** in other sections, chapters, or manuals.

1 Introduction



FURTHER INFORMATION!

This symbol is used in the tables and refers to **further information** in connection with the table.



DISPOSAL!

This device and the batteries (if installed) must not be disposed in the garbage can after use! Please ensure that they are disposed properly and in an **environmentally friendly manner**.

1.1.3 Representation

Menu structure

The > symbol between words indicates a menu structure and enables the parameters to be quickly detected in the configuration level or for navigation in the setup program, such as the software version of the devices, for example:

DEVICE MENU > GENERAL > VERSION > SW VERSION

Active input

The device has no buttons and is operated using a finger or a pen.

The following instructions will therefore make references to **"touching"** and the images displayed will show a hand operating the device.

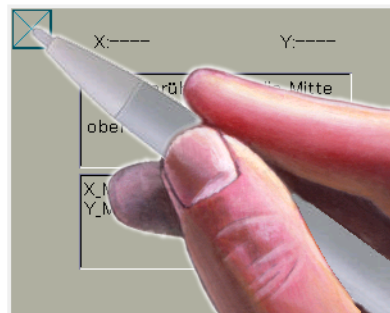
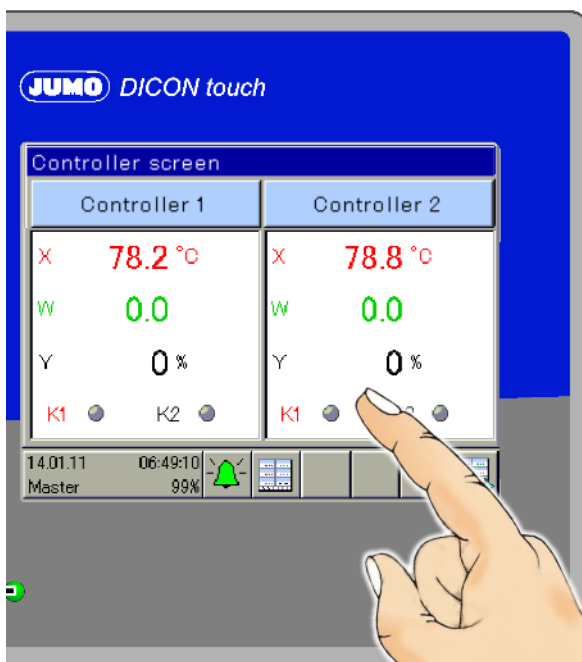

1.2 Description

The DICON touch is a two-channel universal process and program controller that displays information on a vibrant screen. The device is easy to operate via a touchscreen.

Both control channels use the tried-and-tested JUMO control algorithm with two possible optimization options. These enable a simple and highly-accurate startup. It also enables multiple zone control, cascade control, or other complex control tasks.

The block diagram below illustrates the various different hardware options offered by the modular hardware concept. Four analog universal inputs and up to eight external inputs can record a variety of physical measured values with high precision. The actuators can be controlled directly in the device with either an analog or digital setup. These can be expanded further through external digital outputs. Interfaces such as Modbus (master/slave), PROFIBUS, PROFINET-RT or Ethernet with Web server can be used for the communication with higher-order systems.

To ensure secure process operation, the device has a password-protected user administration with individual assignment of rights for different levels or control commands. Screen masks for controllers, program generators, recording, and for overview screens are ready-made and available. An individual process screen can be created using the configuration software. Using the extra-code recording function, important analog and digital process values can be saved so that they are tamper-proof, so that they can be graphically visualized, and so that they can be exported via interface or USB stick in a tamper-proof fashion to the PC.

The configuration software ensures that the process controller can be easily programmed, that math or logical coherences can be described, and that customer-specific linearizations can be created. In addition, tools for simulating external signals or control paths are included. These tools can also record for the duration of the startup.

A comprehensive alarm and limit-value concept as well as a flexible digital signal administration complete the "all-in-one" device.

1 Introduction

1.3 Block diagram

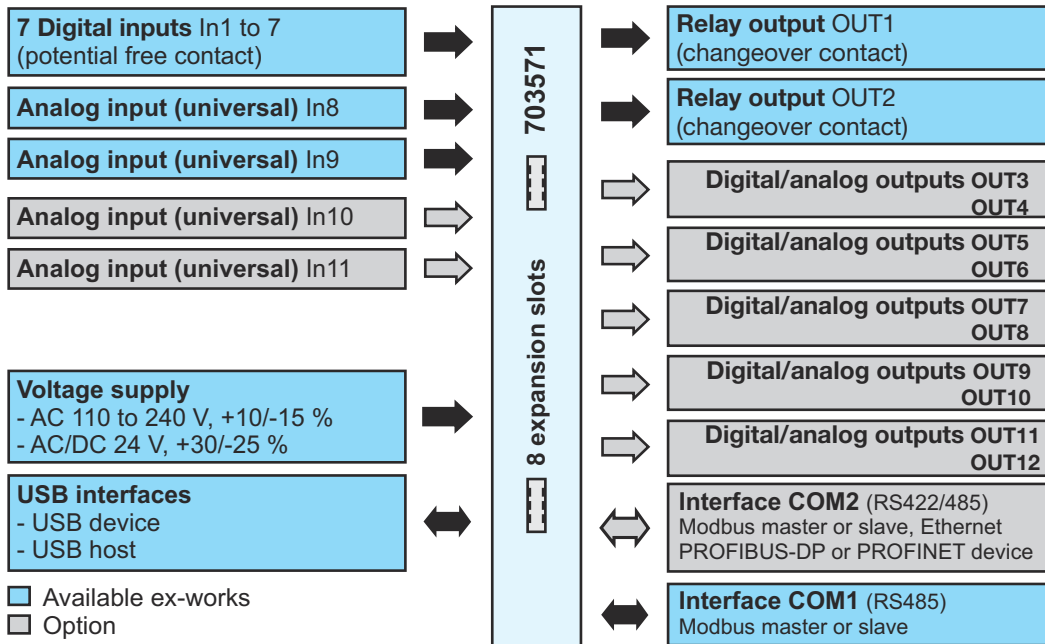

2 Identifying the device version

2.1 Order details

(1) Basic type	
703571	JUMO DICON touch - two-channel process and program controller with RS485 interface
(2) Version	
8	Standard with default settings
9	Customer-specific configuration (specifications in plain text)
(3) National language of display texts	
01	German
02	English
03	French
(4) Input IN10	
00	Not used
10	Analog input (universal)
(5) Input IN11	
00	Not used
10	Analog input (universal)
(6) Outputs OUT3/4	
00	None
11	One relay (changeover contact)
12	Two relays (N/O contact)
13	One solid-state relay 230 V, 1 A
14	One logic output DC 0/22 V max. 30 mA
15	Two logic outputs 0/12 V, 20 mA
16	One analog output
17	Two PhotoMOS® relays ¹
20	Two solid state relays 230 V, 1 A for motor actuator (double slot: OUT3/4 and OUT7/8)
(7) Outputs OUT5/6	
00	None
11	One relay (changeover contact)
12	Two relays (N/O contact)
13	One solid-state relay 230 V, 1 A
14	One logic output 0/22 V, max. 30 mA
15	Two logic outputs 0/12 V, 20 mA
16	One analog output
17	Two PhotoMOS® relays ^a
20	Two solid state relays 230 V, 1 A for motor actuator (double slot: OUT5/6 and OUT9/10)
(8) Outputs OUT7/8 (not available for assignment with module 20 on OUT3/4)	
00	None

2 Identifying the device version

11	One relay (changeover contact)
12	Two relays (N/O contact)
13	One solid-state relay 230 V, 1 A
14	One logic output 0/22 V, max. 30 mA
15	Two logic outputs 0/12 V, 20 mA
16	One analog output
17	Two PhotoMOS® relays ^a
(9) Outputs OUT9/10 (not available for assignment with module 20 on OUT5/6)	
00	None
11	One relay (changeover contact)
12	Two relays (N/O contact)
13	One solid-state relay 230 V, 1 A
14	One logic output 0/22 V, max. 30 mA
15	Two logic outputs 0/12 V, 20 mA
16	One analog output
17	Two PhotoMOS® relays ^a
(10) Outputs OUT11/12	
00	None
11	One relay (changeover contact)
12	Two relays (N/O contact)
13	One solid-state relay 230 V, 1 A
14	One logic output 0/22 V, max. 30 mA
15	Two logic outputs 0/12 V, 20 mA
16	One analog output
17	Two PhotoMOS® relays ^a
(11) Voltage supply	
23	AC 110 to 240 V +10/-15 %, 48 to 63 Hz
39	AC/DC 24 V +30/-25 %, 48 to 63 Hz
(12) COM2 interface	
00	Not used
08	Ethernet
54	RS422/485 Modbus RTU
63	PROFINET ²
64	PROFIBUS-DP
(13) DIN-tested	
000	Without approval
056	With DIN approval
(14) GL-tested	
000	Without approval
062	With GL approval

2 Identifying the device version

(15) Extra code	
000	Without extra code
213	Recording function
214	Math and logic module
223	Program controller
879	AMS2750/CQI-9 ³

¹ PhotoMOS is a registered trademark of Panasonic Corporation

² In conjunction with PROFINET no GL and DIN approval available

³ For the calibration certificate the channels to be checked are to be defined with the thermocouple type and the desired measuring points.

Order code (1) / (2) - (3) - (4) (5) - (6) (7) (8) (9) (10) - (11) - (12) / (13) , (14) , (15)
 / - - - - - / , , ...¹
Order example 703571 / X - X - X X - X X X X X - X - X / X , X , X

¹ List extra codes in sequence, separated by commas.

2.2 Scope of delivery







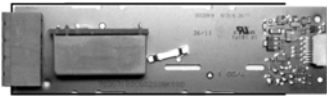
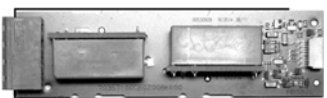

- 1 controller in the ordered version
- 1 Operating Manual
- 1 panel seal 4 retaining elements for panel installation

2.3 General accessories

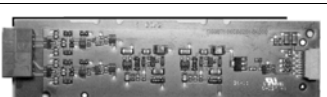
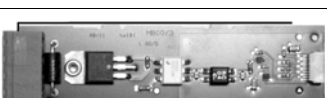
Article	Part no.
Program editor/startup	00607139
Setup/program editor	00606496
PCA3000/PCC JUMO software package 709701/709702	00431884
USB cable A-connector mini B-connector 3 m	00506252

2 Identifying the device version

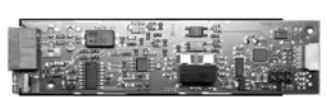
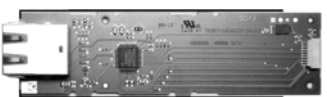
2.4 Accessories

Item		Parts no.
Modules for expansion slots:		
One analog input (universal)		00581159
One relay output (changeover contact)		00581160
Two relay outputs (N/O contact)		00581162
One logic output DC 0/22 V, max. 30 mA		00581165
Two logic outputs DC 0/12 V max. 20 mA		00581168
One solid state relay AC 230 V, 1 A		00581164
Two solid state relays AC 230 V, 1 A for motor actuator		00621574
Two PhotoMOS® relays ¹ DC 45 V, max. 200 mA, AC 30 V, max. 200 mA		00581171
One analog output (universal)		00581169
Ethernet interface		00581174
Serial interface RS422/RS485		00581172
PROFIBUS-DP interface		00581173

¹ PhotoMOS is a registered trademark of Panasonic Corporation

2 Identifying the device version

2.5 Nameplate

Position

The nameplate is affixed to the case.

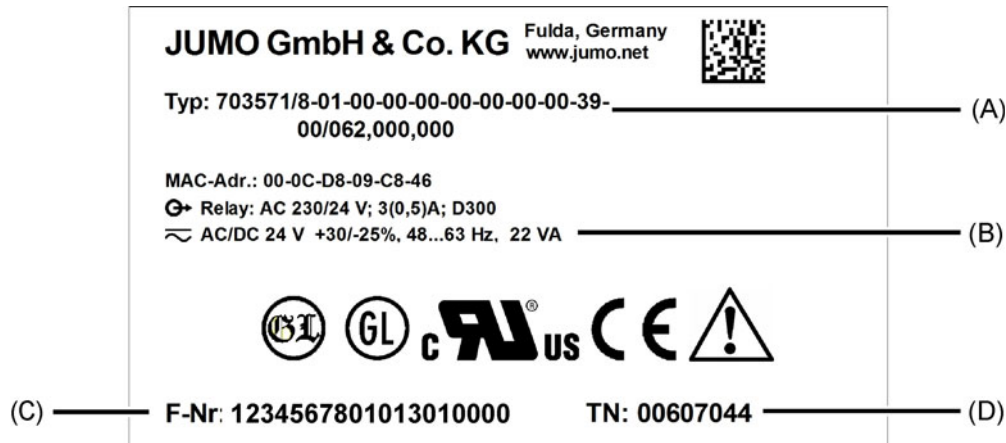

Contents

The nameplates contain important information. This includes:

Description	Designation on the nameplate
Device type (A)	Type
Voltage supply, power consumption (B)	
Fabrication number (C)	F-No.
Part no. (D)	TN

Device type

Compare the specifications on the nameplate with the order.

Identify the supplied device version using the order details (order code).

Part no. (PN)

The part no. clearly identifies an article in the catalog. It is important for communication between the customer and the sales department.

Fabrication number (F-No.:

Among other things, the fabrication number contains the date of production (year/week).

Example: F-No. = 1234567801013010000

The figures in question are in positions 12, 13, 14, and 15 (from the left).

The device was therefore produced in the 1st calendar week of 2013.

Identifying the optional modules

The device type also contains information about optional default modules, as in the following example of the Ethernet interface (Figure 08):

703571/8-01-00-00-00-00-00-00-25-08... (see type key)

Further information on identifying optional modules is included in this chapter:

⇒ B 703571.0 - Chapter 9.2 "Slots", page 51

2 Identifying the device version

3.1 Mounting site and climatic conditions

The mounting site should be free from vibration, dust and corrosive media. Install controllers as far away as possible from sources of electromagnetic fields, such as those created by frequency converters or high-voltage ignition transformers. Conditions at the mounting site must correspond to the following environmental influences:

3.1.1 Environmental influences

Ambient/storage temperature range	-5 to +55 °C/-30 to +70 °C
Resistance to climatic conditions	Humidity 3K3 (DIN EN 60721-3-3) with extended temperature range, rel. humidity ≤ 95 % mid-year without condensation

3.1.2 Electrical data

Voltage supply Connection Voltage	At the back via screw terminals AC/DC 24 V +30/-25%, 48 to 63 Hz or AC 110 to 240 V +10/-15 %, 48 to 63 Hz	
Power consumption	At voltage supply 230 V: max. 15 VA / 7 W At voltage supply 24 V: max. 12 VA / 9 W	
Inputs and outputs Connection Conductor cross section	At the back via screw terminals Max. 2.5 mm ² , wire or strand with end sleeve	
Electrical safety	According to DIN EN 61010-1 Overvoltage category III, pollution degree 2	
Electromagnetic compatibility Interference emission Interference immunity	According to DIN EN 61326-1 Class A - For industrial applications only Industrial requirements	
Memory data recorder	Memory cycle	Recording interval
When recording:	1 s	approx. 44 days
4 analog signals	5 s	approx. 220 days
3 digital signals	10 s	approx. 441 days
	60 s	approx. 2646 days (7 years, 91 days)

3.1.3 Case

Site Altitude	maximum 2000m above sea level
Case type	Plastic front frame with metal case barrel (for indoor use only)
Front frame dimensions	96 mm × 96 mm
Panel cut-out	92 ^{+0.8} mm × 92 ^{+0.8} mm according to DIN IEC 61554
Close mounting	Spacing between the panel cut-outs, min. 35 mm horizontally and min. 80 mm vertically

3 Mounting

Panel thickness	Max. 5 mm
Depth behind panel	Max. 130 mm
Mounting	Four mounting brackets
Operating position (including the viewing angle of the TFT color screen)	Any Horizontal $\pm 65^\circ$, vertical $+40$ to -65°
Protection type	Front IP66, rear IP20, according to DIN EN 60529
Weight (fully fitted)	approx. 1000 g

3.2 Dimensions

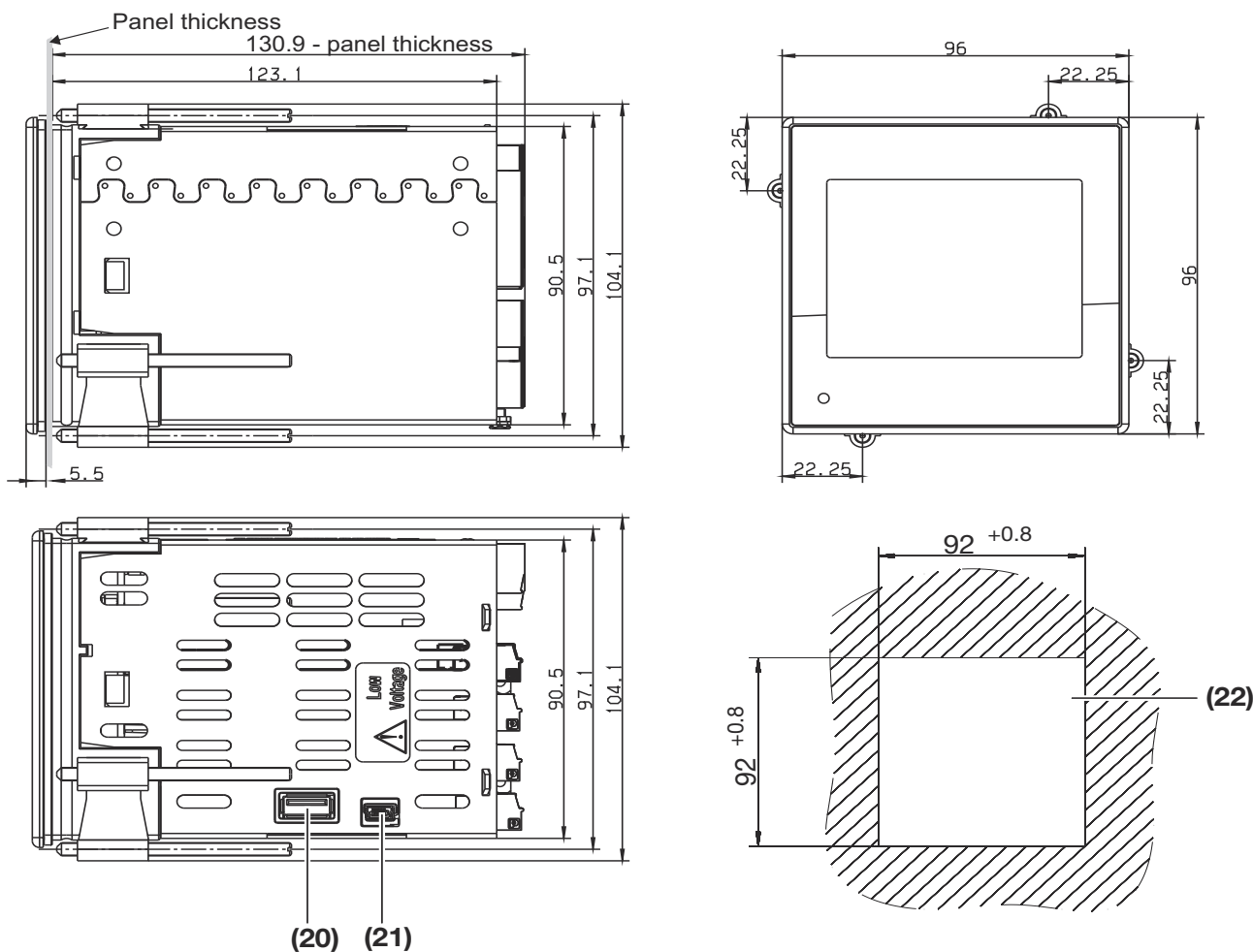

(20) USB host interface

(21) USB device interface for setup

(22) Panel cut-out

3.3 Close mounting

If several devices are mounted on a switch board above or next to each other, the panel cut-outs must be positioned 35 mm horizontally and at least 80 mm vertically away from each other.

3.4 Insertion in panel cut-out

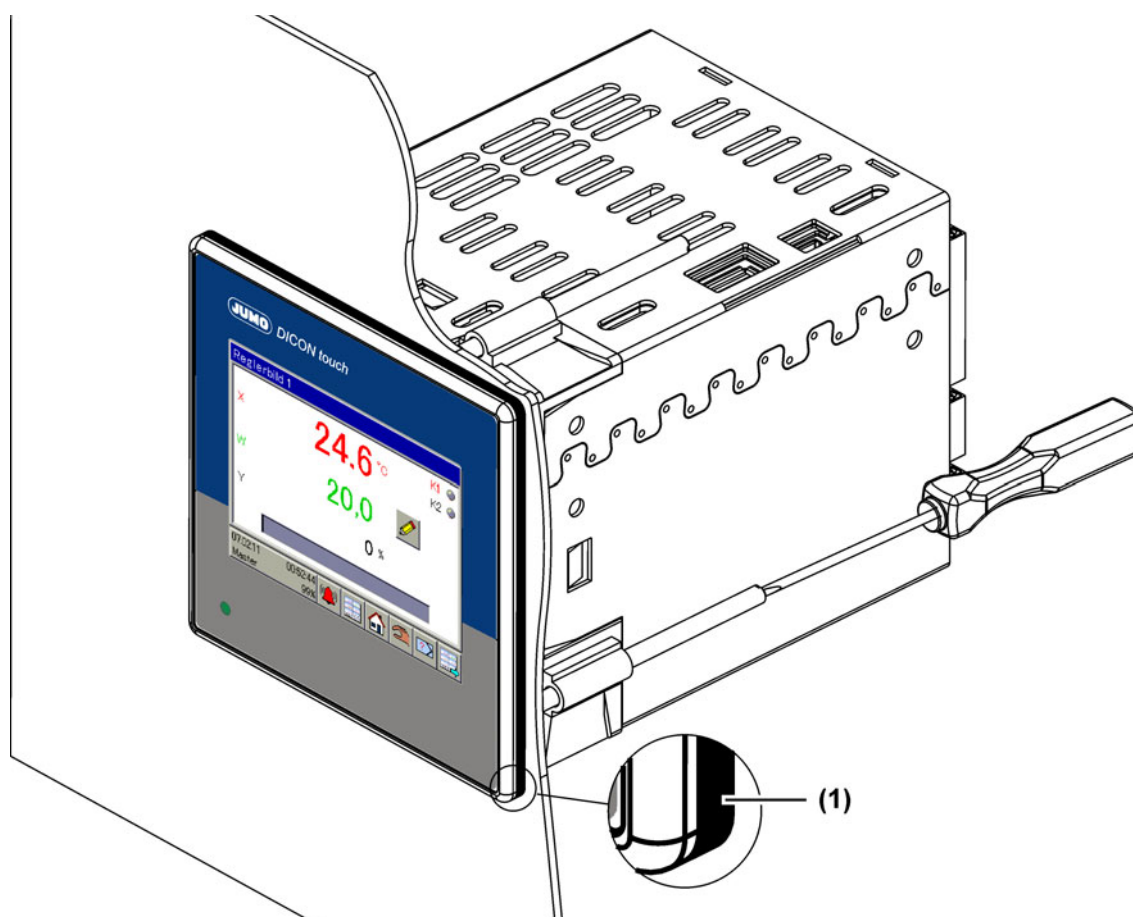

Step	Activity
1	Affix delivered panel seal (1) on the device from the rear
2	Insert the device into the panel cut-out from the front and ensure the panel seal is correctly positioned so that no water or dirt can penetrate the case.
3	From the panel rear, slide the mounting brackets into the guides on the sides of the case. In doing so, the flat faces of the mounting brackets must make contact with the case.
4	Place the mounting brackets against the panel rear and tighten evenly with a screwdriver until the controller housing is firmly positioned in the panel cut-out.

3.5 Care and treatment of the front cover

The front plate can be cleaned with commercial detergents and cleaning agents.

3 Mounting



NOTE!

The resistive touchscreen cover reacts to finger pressure or can be operated using commercially available pens with a rounded plastic tip.



CAUTION!

Sharp tools can scratch and damage the cover.
The front plate is not resistant to corrosive acids or lyes, abrasives, or cleaning with high-pressure cleaners.
Do not use sharp objects near the device.

4.1 Installation notes

**CAUTION!**

The delivery status of the device at the first startup does not necessarily correspond to the intended application (for example, Controller 2 inactive).

This may result in undefined plant behavior.

Therefore, where possible during startup, no actuators should be connected and load current circuits should be isolated. The plant installer is essentially responsible for the startup process.

4.1.1 Cables, shielding, and grounding

When selecting the electrical wiring material as well as when installing and connecting the controller electrically, comply with the requirements of DIN VDE 0100 "Low-voltage electrical installations" and the applicable country-specific regulations (for example, based on IEC 60364).

- Where possible, route input, output, and supply cables separately and not parallel to one another.
- Only use shielded and twisted probe and interface cables and where possible, route them at a distance from components or lines that are live.
- For temperature probes, ground the shielding on one side in the control cabinet.
- Do not perform loophroughs on the grounding cables, but route the cables individually to a shared grounding point in the control cabinet; in doing so, ensure that the cables are as short as possible.
- Ensure potential equalizer is correctly routed.
- At maximum load, the cables must be heat resistant up to at least 80°C.
- When connecting the device to an external PELV electrical circuit, the existing internal SELV electrical circuit becomes a PELV electrical circuit whereby the protection against electrical shock is provided through double/reinforced insulation and voltage limitation – but here no connection to the protective ground is required.

4.1.2 Electrical safety

- The primary fuse protection for the voltage supply should not exceed a value of 20 A (passive) and should not be less than 2 A.
- In order to prevent the destruction of the relay or solid state relay outputs in the event of an external short circuit in the load circuit, the load circuit should be fused to the maximum admissible output current.
- In addition to a faulty installation, incorrectly set values on the controller could also impair the correct function of the following process. Therefore, ensure that safety devices independent of the controller (for example, overpressure valves or temperature limiters/monitors) are available and that it is only possible for qualified personnel to define settings. Please observe the corresponding safety regulations in this context.
- Since not all existing control paths can be controlled with the setting function, the stability of the actual value reached should be monitored.
- For servicing/repairing a Disconnecting Device shall be provided to disconnect all conductors.

4 Electrical connection

4.1.3 Intended use, misuse

- The controller is intended for use in the industrial sector.



WARNING!

The controller is not suitable for installation in areas with an explosion hazard. There is the risk of an explosion. The device must only be used outside of areas with an explosion hazard.

4.2 Galvanic isolation

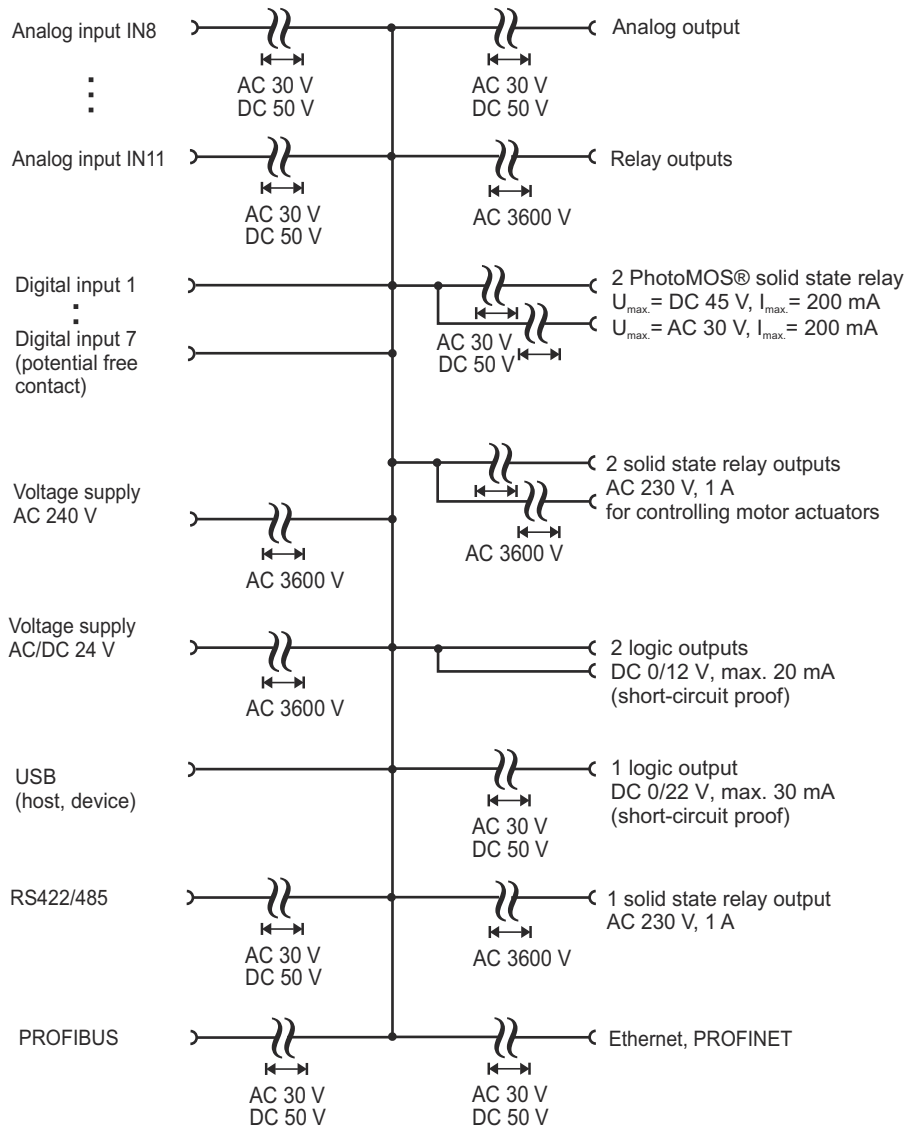

4.3 Connection diagram



DANGER!

Works involving dangerous electrical voltage (230 V) are performed here. There is a risk of electric shock.

Switch off all voltage circuits before routing. The electrical connection must only be carried out by qualified personnel.

4.3.1 Connection elements

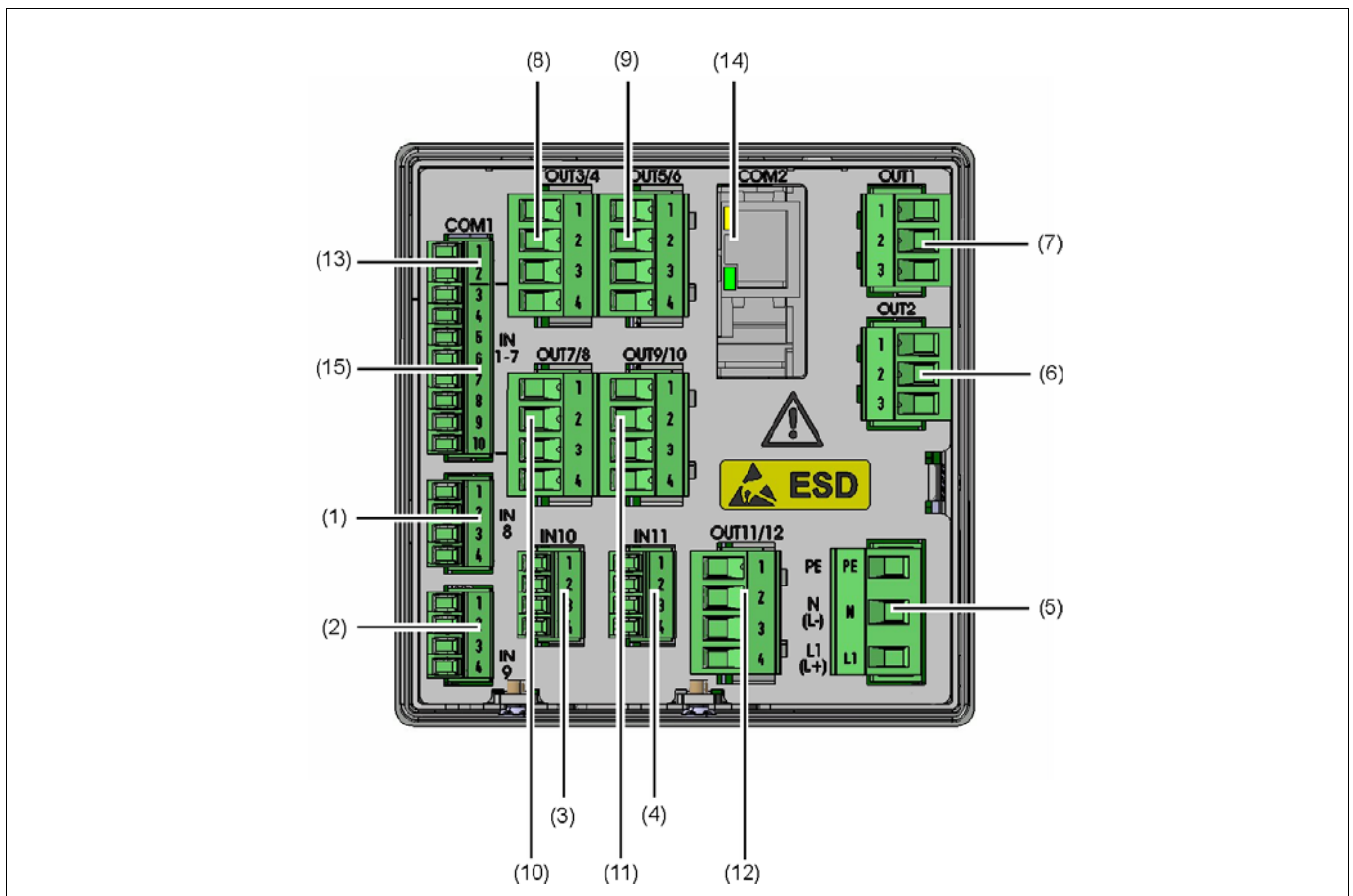



- | | |
|---|--|
| (1) Analog input IN8 | (2) Analog input IN9 |
| (3) Expansion slot for analog input IN10 | (4) Expansion slot for analog input IN11 |
| (5) Voltage supply
AC 240 V +10/-15 %, 48 to 63 Hz, max. 38.1 VA
AC/DC 24 V +30/-25%, 48 to 63 Hz,
max. 21.9 VA / 11.5 W | (6) Relay output OUT2 |
| (7) Relay output OUT1 | (8) Expansion slot for outputs OUT3/4 |
| (9) Expansion slot for outputs OUT5/6 | (10) Expansion slot for outputs OUT7/8 |
| (11) Expansion slot for outputs OUT9/10 | (12) Expansion slot for outputs OUT11/12 |
| (13) COM1 interface RS485 | (14) Expansion slot for COM2 interface |
| (15) Digital inputs IN1 to 7 | |

4 Electrical connection

4.3.2 Analog inputs

Input IN8, IN9 as standard

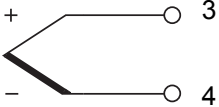
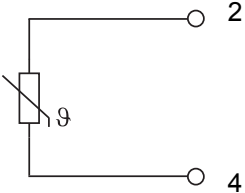
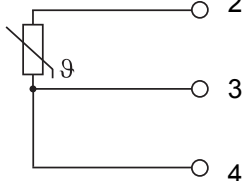
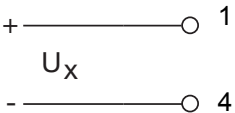
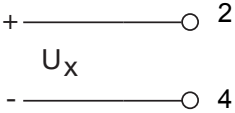
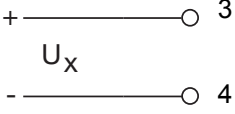
Two analog inputs can be added to input (IN10), (IN11) optional boards

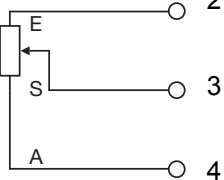
Connection	(Connection element) Input	Symbol and terminal designation
Thermocouple	(1) IN8 (2) IN9 (3) IN10 (4) IN11	
RTD temperature probe Two-wire circuit		
RTD temperature probe Three-wire circuit		
Voltage DC 0(2) to 10 V		
Voltage DC 0 to 1 V		
Voltage DC 0 to 100 mV		
Current DC 0(4) to 20 mA		
Resistance transmitter		

A = Start
E = End
S = Slider

4.3.3 Probes for the operating medium air

Note: Because of the high response accuracy, the use of **thermowells** (pockets) is **not admissible**.

Actual type designation	Old type designation	Probe type	Temperature range	Nom. length mm	Process connection
RTD temperature probe Data Sheet 90.2006					
902006/65-228-1003-1-15-500-668/000	-	1 x Pt100	-170 ... +700°C	500	
902006/65-228-1003-1-15-710-668/000	-			710	
902006/65-228-1003-1-15-1000-668/000	-			1000	
902006/55-228-1003-1-15-500-254/000	-	1 x Pt100	-170 ... +700°C	500	
902006/55-228-1003-1-15-710-254/000	-			710	
902006/55-228-1003-1-15-1000-254/000	-			1000	
902006/65-228-2003-1-15-500-668/000	90.271-F01	2 x Pt100	-170 ... +700°C	500	Stop flange, movable
902006/65-228-2003-1-15-710-668/000	90.272-F01			710	
902006/65-228-2003-1-15-1000-668/000	90.273-F01			1000	
902006/55-228-2003-1-15-500-254/000	-	2 x Pt100	-170 ... +700°C	500	movable G1/2 compression clamp
902006/55-228-2003-1-15-710-254/000	-			710	
902006/55-228-2003-1-15-1000-254/000	-			1000	
Thermocouples Data Sheet 90.1006					
901006/65-547-2043-15-500-668/000	90.019-F01	2 x NiCr-Ni, Type „K“	-35 ... +800°C	500	Stop flange, movable
901006/65-547-2043-15-710-668/000	90.020-F01			710	
901006/65-547-2043-15-1000-668/000	90.021-F01			1000	
901006/65-546-2042-15-500-668/000	90.019-F11	2 x Fe-CuNi, Type „L“	-35 ... +700°C	500	
901006/65-546-2042-15-710-668/000	90.020-F11			710	
901006/65-546-2042-15-1000-668/000	90.021-F11			1000	
901006/66-550-2043-6-500-668/000	90.023-F01	2 x NiCr-Ni, Type „K“	-35 ... +1000°C	500	
901006/66-550-2043-6-355-668/000	90.023-F02			355	
901006/66-550-2043-6-250-668/000	90.023-F03			250	
901006/66-880-1044-6-250-668/000	90.021	1 x PT10Rh-PT, Type „S“	0 ... 1300°C	250	
901006/66-880-1044-6-355-668/000	90.022			355	
901006/66-880-1044-6-500-668/000	90.023			500	
901006/66-880-2044-6-250-668/000	90-D-021	2 x PT10Rh-PT, Type „S“	0 ... 1300°C	250	Stop flange, movable
901006/66-880-2044-6-355-668/000	90-D-022			355	
901006/66-880-2044-6-500-668/000	90-D-023			500	

901006/66-953-1046-6-250-668/000	90.027	1 x PT30Rh-PT6Rh, Type „B“	600 ... 1500°C	250	
901006/66-953-1046-6-355-668/000	90.028			355	
901006/66-953-1046-6-500-668/000	90.029			500	
901006/66-953-2046-6-250-668/000	90-D-027	2 x PT30Rh-PT6Rh, Type „B“	600 ... 1500°C	250	
901006/66-953-2046-6-355-668/000	90-D-028			355	
901006/66-953-2046-6-500-668/000	90-D-029			500	

4 Electrical connection

4.3.4 Probes for the operating medium water and oil

Note: Because of the high response accuracy, the use of **thermowells** (pockets) is **not admissible**.

Actual type designation	Old type designation	Probe type	Temperature range	Nom. length mm	Process connection
RTD temperature probe Data Sheet 90.2006					
90.2006/10-402-1003-1-9-100-104/000		1 x Pt100	-40 ... +400°C	100	G1/2 screw connection
90.2006/10-402-2003-1-9-100-104/000		2 x Pt100		100	
902006/54-227-2003-1-15-710-254/000	90.272-F02	2 x Pt100	-170 ... 550°C	65...670	movable G1/2 compression clamp
902006/54-227-1003-1-15-710-254/000	90.272-F03	1 x Pt100		65...670	
902006/10-226-1003-1-9-250-104/000	90.239	1 x Pt100	-170 ... 480°C	250	G1/2 screw connection
902006/10-226-2003-1-9-250-104/000	90-D-239	2 x Pt100		250	
Thermocouples Data Sheet 90.1006					
901006/54-544-2043-15-710-254/000	90.020-F02	2 x NiCr-Ni, Type „K“	-35 ... 550°C	65...670	movable G1/2 compression clamp
901006/54-544-1043-15-710-254/000	90.020-F03	1 x NiCr-Ni, Type „K“		65...670	
901006/54-544-2042-15-710-254/000	90.020-F12	2 x FeCuNi, Type „L“		65...670	
901006/54-544-1042-15-710-254/000	90.020-F13	1 x FeCuNi, Type „L“		65...670	

Note: Because of the high response accuracy, **only use thermowells** (pockets) that are **included in the scope of delivery**.

Actual type designation	Old type designation	Probe type	Temperature range	Nom. length mm	Process connection
RTD temperature probe Data Sheet 90.2006					
902006/53-505-2003-1-12-190-815/000	90D239-F03	2 x Pt100	-40 ... +400 °C	190	
902006/53-507-2003-1-12-100-815/000	90.239-F02	2 x Pt100 (arranged one below the other in protection tube)	-40 ... +480 °C	100	
902006/53-507-2003-1-12-160-815/000	90.239-F12			160	
902006/53-507-2003-1-12-190-815/000				190	
902006/53-507-2003-1-12-220-815/000	90.239-F22			220	
902006/53-507-1003-1-12-100-815/000	90.239-F01	1 x Pt100	-40 ... +480 °C	100	weld-in sleeve
902006/53-507-1003-1-12-160-815/000	90.239-F11			160	
902006/53-507-1003-1-12-220-815/000	90.239-F21			220	
902006/53-505-1003-1-12-190-815/000	90.239-F03	1 x Pt100	-40 ... +400 °C	190	
902006/53-505-3003-1-12-100-815/000	90.239-F07	3 x Pt100	-40 ... +400 °C	100	
902006/53-505-3003-1-12-160-815/000	90.239-F17			160	
902006/53-505-3003-1-12-220-815/000	90.239-F27			220	
902006/40-226-1003-1-12-220-815/000	90.280-F30	1 x Pt100	-170 ... +480°C	220	weld-in sleeve
902006/40-226-1003-1-12-160-815/000	90.280-F31			160	
902006/40-226-1003-1-12-100-815/000	90.280-F32			100	
Thermocouples Data Sheet 90.1006					
901006/53-543-1042-12-220-815/000	90.111-F01	1 x Fe-CuNi Type „L“	-35 ... 480°C	220	weld-in sleeve
901006/53-543-2042-12-220-815/000	90.111-F02	2 x Fe-CuNi Type „L“		220	

4.3.5 Probes for the operating medium water, oil and air

Note: Because of the high response accuracy, the use of **thermowells** (pockets) is **not admissible**.

Actual type designation	Old type designation	Probe type	Temperature range	Install. length mm	Process connection
RTD temperature probe Data Sheet 90.2006					
90.2006/10-390-1003-1-8-250-104/000	90.210-F95	1 x Pt100	max. 300°C	250	
Thermocouples Data Sheet 90.1006					
901006/45-551-2043-2-xxxx-11-xxxx		2 x NiCr-Ni, Type „K“	max. 1150°C	50...2000	

4 Electrical connection

4.3.6 Analog outputs

One analog output can be added to output OUT 3/4 to 11/12 using optional boards

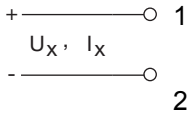
Connection	(Connection element) Input	Symbol and terminal designation
One analog output DC 0/2 to 10 V or DC 0/ 4 to 20 mA (configurable)	(8) OUT3/4 (9) OUT5/6 (10) OUT7/8 (11) OUT9/10 (12) OUT11/12	

4.3.7 Digital inputs

Input IN1 to 7 as standard (cannot be extended)

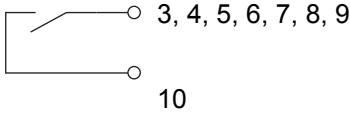
Connection	(Connection element) Input	Symbol and terminal designation
Digital input, potential-free contact as standard	(15) IN1 to 7	

4.3.8 Digital outputs

OUT1 and OUT2 as standard

The controller is fitted with two relay outputs (changeover contacts) as standard.

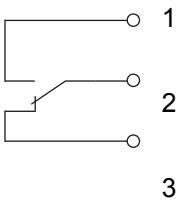
Connection	(Connection element) Output	Symbol and terminal designation
Relay output (changeover contact)	(6) OUT2 (7) OUT1	

4 Electrical connection

Outputs OUT 3/4 to 11/12 are expandable using the following optional boards

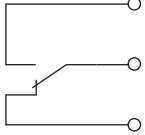
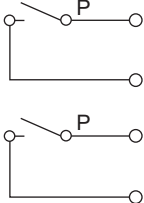
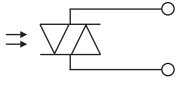
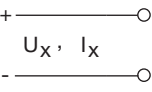
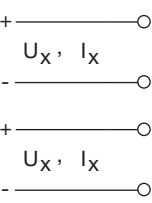
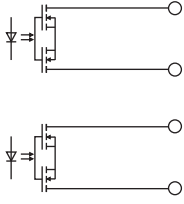
Connection	(Connection element) Output	Symbol and terminal designation
One relay output (changeover contact)	(8) OUT3/4 (9) OUT5/6 (10) OUT7/8 (11) OUT9/10 (12) OUT11/12	 <p>1 2 3</p>
Two relay outputs (N/O contact) ¹		 <p>1 2 3 4</p>
One solid state relay AC 230 V, 1 A		 <p>1 2</p>
One logic output DC 0/22 V, max. 30 mA (short-circuit proof)		 <p>1 2</p>
Two logic outputs DC 0/12 V max. 20 mA (short-circuit proof, not galvanically isolated from each other)		 <p>1 2 3 4</p>
Two PhotoMOS® relays ² max. DC 45 V, 200 mA max. AC 30 V, 200 mA (galvanically isolated)		 <p>1 2 3 4</p>

4 Electrical connection

Connection	(Connection element) Output	Symbol and terminal designation
Two solid state relays AC 230 V, 1 A (for controlling the left and right-hand motor actuators, galvanically isolated)		

¹ Combining a mains voltage circuit with a protective low-voltage circuit on the "dual normally open contact" option is not admissible.

² PhotoMOS is a registered trademark of Panasonic Corporation.

4.3.9 Digital outputs

Standard

Two relay outputs (changeover contact)	
Switching capacity AC	AC 230V/24V; 3(0,5) A; $\cos\varphi=1(\geq 0,6)$; D300
Switching capacity DC	DC 24V; 3(0,5; $\tau =7\text{ms}$) A
Contact life	250,000 operations at nominal load

Per optional board

One relay output (changeover contact)	
Switching capacity AC	AC 230V/24V; 3(0,5) A; $\cos\varphi=1(\geq 0,6)$; D300
Switching capacity DC	DC 24V; 3(0,5; $\tau =7\text{ms}$) A
Contact life	250,000 operations at nominal load
Two relay outputs (N/O contact) ¹	
Switching capacity AC	AC 230V/24V; 3(0,5) A; $\cos\varphi=1(\geq 0,6)$; D300
Switching capacity DC	DC 24V; 3(0,5; $\tau =7\text{ms}$) A
Contact life	250,000 operations at nominal load
One solid state relay	
Switching capacity	1 A at AC 230 V, resistive load
Protection circuitry	Varistor
Two solid state relay for motor actuators	
Switching capacity	1 A at AC 230 V,
Protection circuitry	RC combination
One logic output (voltage supply for transmitter)	DC 0/22 V, max. 30 mA (short-circuit proof)
Two logic outputs	DC 0/12 V max. 20 mA (short-circuit proof, not galvanically isolated)
Two PhotoMOS® relays ²	DC 45 V, max. 200 mA, (galvanically isolated from each other, not short-circuit proof) AC 30 V, max. 200 mA, (galvanically isolated from each other, not short-circuit proof)

4 Electrical connection

¹ Combining a mains voltage circuit with a protective low-voltage circuit on the "dual normally open contact" option is not admissible.

² PhotoMOS is a registered trademark of Panasonic Corporation.

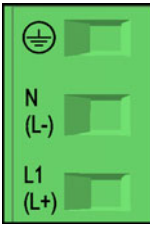

4.3.10 Voltage supply (according to nameplate)

AC 230V (DC 24V)



Connection	(Connection element)	Symbol and terminal designation
Protection conductor	PE	 PE
Neutral conductor	N (L-)	N
Line conductor	L1(L+)	L1

4.3.11 Interfaces

USB device, USB host and COM1 interfaces as standard

Connection	(Connection element)	Symbol and terminal designation				
USB device interface	(21)					
USB host	(20)					
COM1 serial interface RS485 (galvanically isolated)	(13)	 <table border="0" style="display: inline-table; vertical-align: middle;"> <tr> <td>1 TxD+/RxD+</td> <td>Transmission/ received data +</td> </tr> <tr> <td>2 TxD-/RxD-</td> <td>Transmission/ received data -</td> </tr> </table>	1 TxD+/RxD+	Transmission/ received data +	2 TxD-/RxD-	Transmission/ received data -
1 TxD+/RxD+	Transmission/ received data +					
2 TxD-/RxD-	Transmission/ received data -					

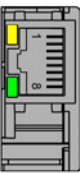
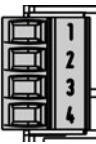
COM2 interface can be expanded using optional boards

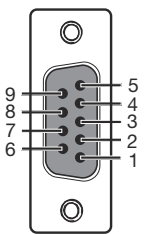
Connection	(Connection element)	Symbol and terminal designation								
Ethernet	(14)	 <table border="0" style="display: inline-table; vertical-align: middle;"> <tr> <td>1 TX+</td> <td>Transmission data +</td> </tr> <tr> <td>2 TX-</td> <td>Transmission data -</td> </tr> <tr> <td>3 RX+</td> <td>Received data +</td> </tr> <tr> <td>6 RX-</td> <td>Received data -</td> </tr> </table>	1 TX+	Transmission data +	2 TX-	Transmission data -	3 RX+	Received data +	6 RX-	Received data -
1 TX+		Transmission data +								
2 TX-		Transmission data -								
3 RX+		Received data +								
6 RX-	Received data -									
Serial interface RS422 (galvanically isolated)	 <table border="0" style="display: inline-table; vertical-align: middle;"> <tr> <td>1 RxD+</td> <td>Received data +</td> </tr> <tr> <td>2 RxD-</td> <td>Received data -</td> </tr> <tr> <td>3 TxD+</td> <td>Transmission data +</td> </tr> <tr> <td>4 TxD-</td> <td>Transmission data -</td> </tr> </table>	1 RxD+	Received data +	2 RxD-	Received data -	3 TxD+	Transmission data +	4 TxD-	Transmission data -	
1 RxD+	Received data +									
2 RxD-	Received data -									
3 TxD+	Transmission data +									
4 TxD-	Transmission data -									
Serial interface RS485 (galvanically isolated)	 <table border="0" style="display: inline-table; vertical-align: middle;"> <tr> <td>3 TxD+/RxD+</td> <td>Transmission/ received data +</td> </tr> <tr> <td>4 TxD-/RxD-</td> <td>Transmission/ received data -</td> </tr> </table>	3 TxD+/RxD+	Transmission/ received data +	4 TxD-/RxD-	Transmission/ received data -					
3 TxD+/RxD+	Transmission/ received data +									
4 TxD-/RxD-	Transmission/ received data -									
PROFIBUS-DP	 <table border="0" style="display: inline-table; vertical-align: middle;"> <tr> <td>3 RxD/TxD-P (B)</td> <td>Transmission/ received data +</td> </tr> <tr> <td>5 DGND</td> <td>Ground</td> </tr> <tr> <td>6 VP (+5 V)</td> <td>Voltage supply</td> </tr> <tr> <td>8 RxD/TxD-N (A)</td> <td>Transmission/ received data -</td> </tr> </table>	3 RxD/TxD-P (B)	Transmission/ received data +	5 DGND	Ground	6 VP (+5 V)	Voltage supply	8 RxD/TxD-N (A)	Transmission/ received data -	
3 RxD/TxD-P (B)	Transmission/ received data +									
5 DGND	Ground									
6 VP (+5 V)	Voltage supply									
8 RxD/TxD-N (A)	Transmission/ received data -									

4 Electrical connection

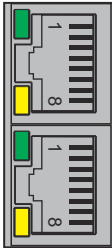
Connection	(Connection element)	Symbol and terminal designation
PROFINET-RT		 <p data-bbox="1034 315 1458 465">1TX+ Transmission data + 2 TX- Transmission data - 3 RX+ Received data + 6 RX- Received data -</p>

5.1 Display and operating concept

The DICON touch is operated via a resistive touchscreen and also reacts to finger pressure. Commercially available pens with plastic tips can also be used.

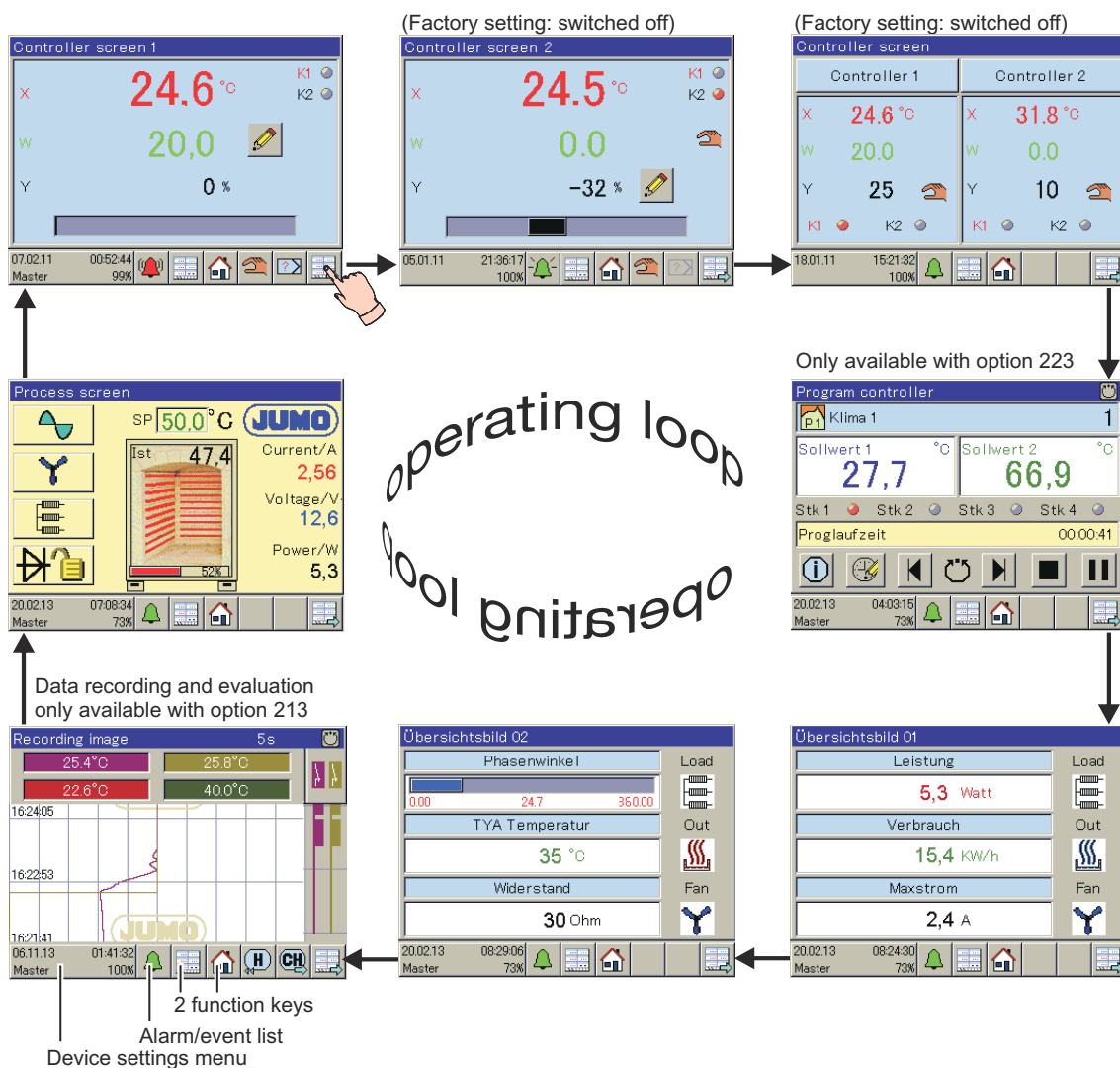
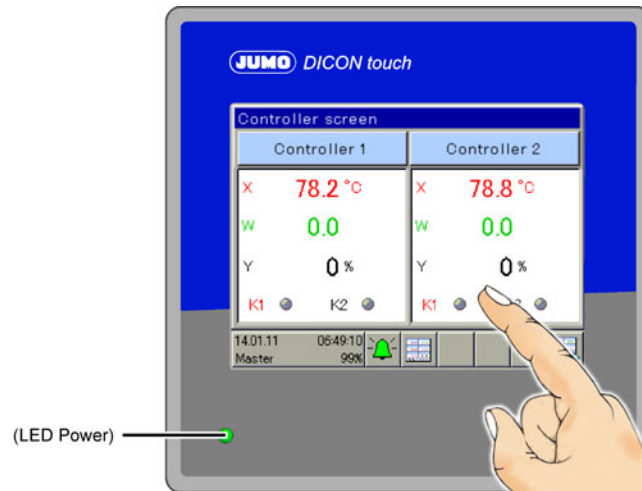

5 Operation

5.2 Device menu

All the functions in the device menu are described in the following sections of the B703571.0de operating manual.

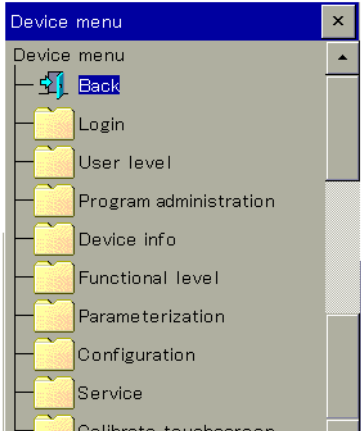
	Chapter 6 "Login", page 41
	B 703571.0 - Chapter 7 "User level (Log-In)", page 45
	Chapter 7 "Program administration", page 43
	B 703571.0 - Chapter 10 "Functional level", page 55
	B 703571.0 - Chapter 8 "Parameterization", page 47
	B 703571.0 - Chapter 12 "Configuration", page 65
Calibrating the touchscreen: Chapter 10 "Special functions", page 61	

5.3 Alarm and event list

In these lists, alarms and events appear that are partly confirmed. Additional entries can be configured to appear in the lists.

- ⇒ B 703571.0 - Chapter 12.9.5 "Alarm", page 105
- ⇒ B 703571.0 - Chapter 12.5.1 "Alarms", page 76

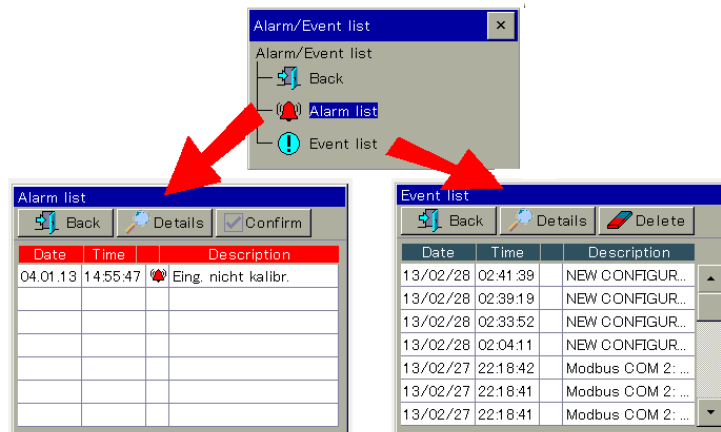

5.4 Function buttons, history and channel changeover

Both these function buttons are set and configurable by default at "Operating level" and "Home" (back to Main view).

- ⇒ B 703571.0 - Chapter 12.10.1 "General configuration", page 106
- The "History"(H) and "Channel changeover"(Ch) buttons enable navigation in the recorder image and change their meaning according to the dialog.
- ⇒ Chapter 5.5.4 "Recording image", page 38

5.5 Images in the operating loop

Start screen

After switch-on, the globe appears until the device software is started up.



Then Controller screen 1 appears (default setting).

Using the icon in the bottom right-hand corner, all the images defined in the operating loop can be called up one after another.

⇒ For the screen settings see B 703571.0 - Chapter 12.10 "Screen", page 106

⇒ To view the images displayed see B 703571.0 - Chapter 12.10.4 "Operating loop", page 108

5.5.1 Controller screen 1, Controller screen 2 and Controller overview

You can change the color of these screens in the setup program.

The basic structure cannot be changed however.

default

Fixed-setpoint controller and Controller 1 are set up.

In order to function properly, the controller requires an actual value, a setpoint value, and an output to influence the actual value (for example, a heat source via a relay as a two-state controller). Self-optimization can only detect new parameters using a closed control loop.

⇒ Chapter 12.6.3 "Self-optimization controller", page 82

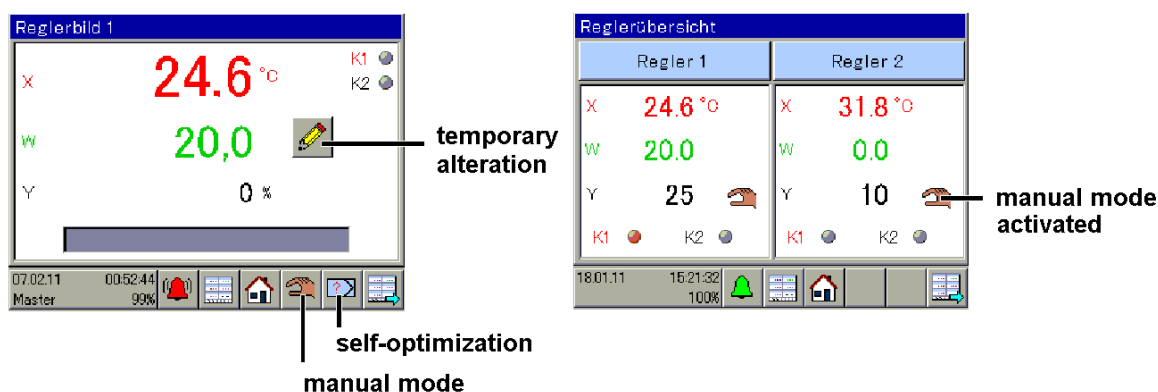

If lines or arrows appear, check the configuration or the connection.

⇒ Chapter 11 "Error and alarm messages", page 63

Enter setpoint values on the device for the fixed-setpoint controller

⇒ Chapter 8.4 "Setpoint values", page 52



Enter setpoint values for the fixed-setpoint controller with the setup program

⇒ Chapter 8.4 "Setpoint values", page 52

5 Operation

Start manual mode

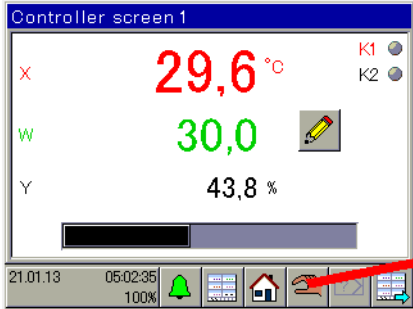
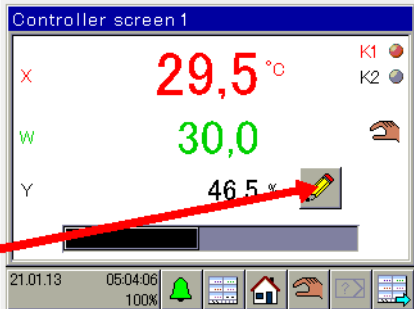
In manual mode, the controller is fixed at a particular output level. First of all, the screens show the active controller, where the output is at approx. 40 %.

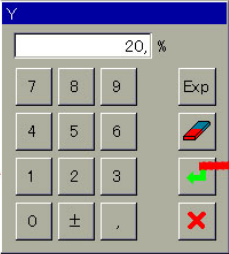
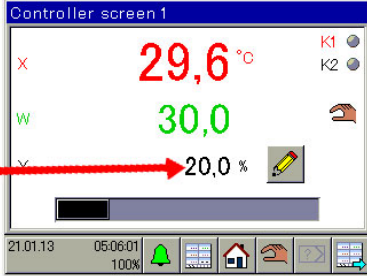
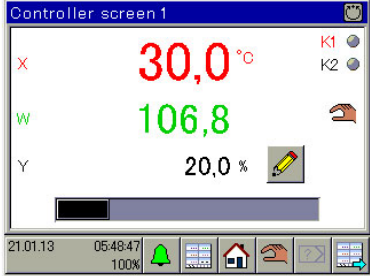
Step	Activity
1	Touch the hand symbol (pencil appears at output level display) <div style="display: flex; justify-content: space-around; margin-top: 10px;">   </div>
2	Touch the pencil, enter the manual output level and confirm (green arrow) <div style="text-align: center; margin-top: 10px;">  </div>
3	The controller operation is interrupted and Controller 1 is now working with a fixed output level of 20 % (the hand symbol appears next to the green setpoint value). You can view the difference between the fixed-setpoint controller and the program controller at the automatic operation icon in the top right-hand corner. The green setpoint value continues, as programmed. <div style="display: flex; justify-content: space-around; margin-top: 10px;">    </div>

➔ You can now manually influence the output level (by hand)

Exit manual mode

By touching the screen below the hand, you can exit manual mode and return to normal controller operation.

Self-optimization

⇒ B 703571.0- Chapter 12.6.3 "Self-optimization controller", page 82

5.5.2 Program controller



TIP!

This screenshot is not available by default and only appears if the extra code for the program controller is enabled and configured.

⇒ Chapter 2.1 "Order details", page 11

default

There are no programs available. The following options are available for ordering a program:

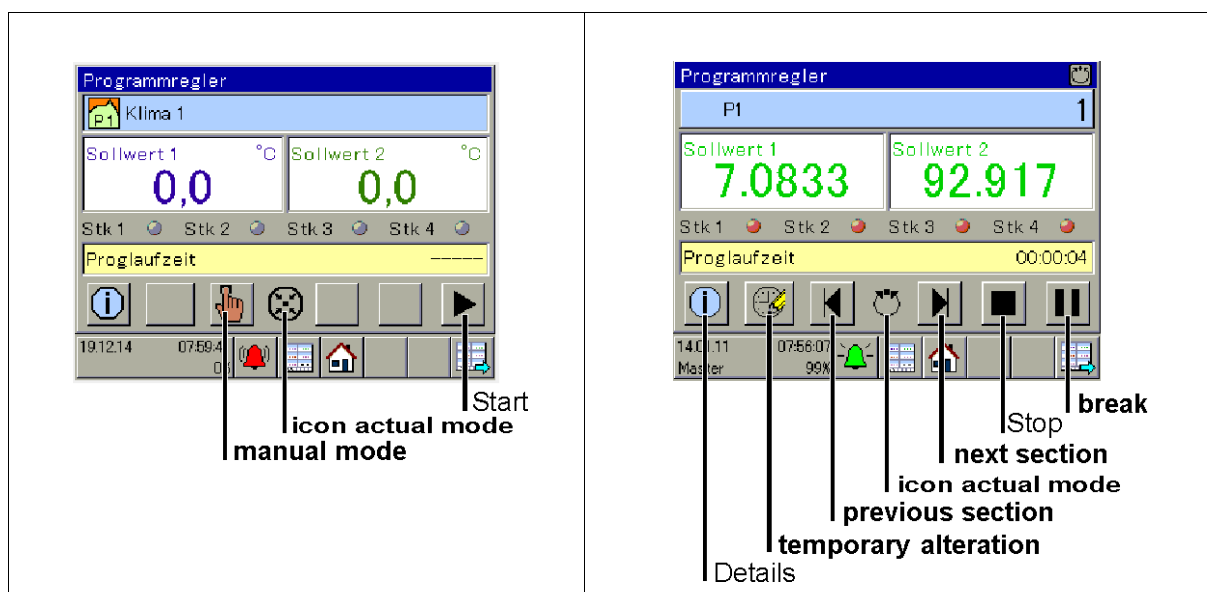

Enter setpoint curves on the device

⇒ Chapter 7.1.1 "On the device", page 43

Enter setpoint curves using the setup program

⇒ Chapter 7.1.2 "About the setup program", page 44

Start, Stop

The black arrow starts an available program. A request appears asking which program should be started and the programmed setpoint curves are then synchronized for both controller channels. The symbol for automatic operation appears in the center. Touching the black rectangle stops the program, adopting the conditions prior to the program starting.

Pause

Pauses the time base of a program in operation, whereby the current setpoint values and the conditions of the control contacts are maintained. Touching the pause button again resumes program operation.

Next section, previous section

The program in operation jumps to the next or previous section.

Temporary alteration

Allow one-time changes to the setpoint values for a program without storing it permanently in the program table. When you next run the program, the original setpoint values will be reactivated.

Start/stop manual mode (for program controller)

Manual mode is performed exactly as for a fixed-setpoint controller.

5 Operation

⇒ Chapter 5.5.1 "Controller screen 1, Controller screen 2 and Controller overview", page 35

Self-optimization

⇒ B 703571.0- Chapter 12.6.3 "Self-optimization controller", page 82

5.5.3 General screen 1.2

default

Two general screens are available that do not contain any variables.

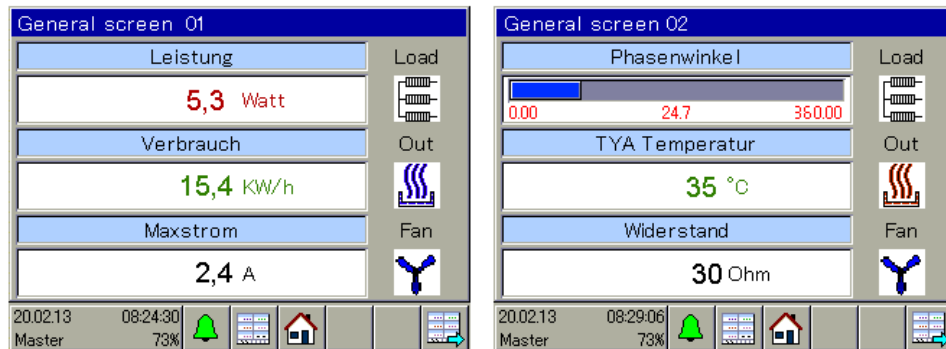

The variables displayed can be configured.

⇒ B 703571.0- Chapter 12.10.8 "General screens 1, 2", page 112

5.5.4 Recording image

default

Here the device is displaying up to four analog and three digital channels, like a line recorder. Extra code 213 is required for data to be recorded and evaluated.

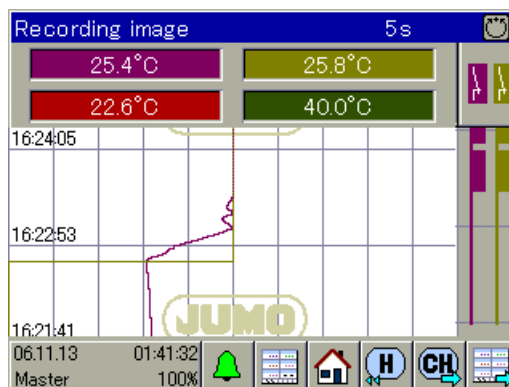

You can view historical data (from previous recordings) with the H button and switch channels with the CH button. If the channels displayed are configured, the screen must still be active for the operating loop display.

⇒ B 703571.0 - Chapter 12.11 "Recording", page 113

5.5.5 Process screen

default

This screen can be freely configured and is empty by default. A background image of your plant can be stored and animated with all the process values for the device.

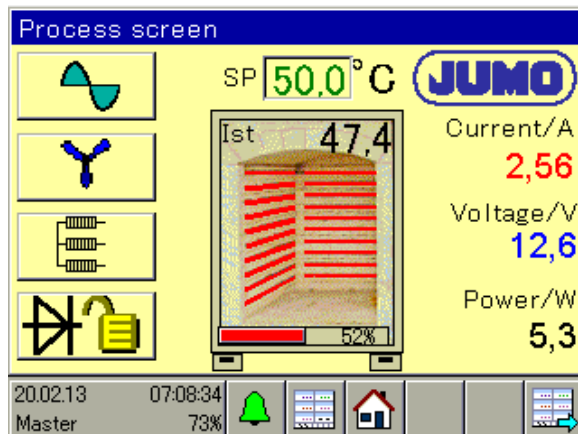

The setup program is required to design the graphics.

⇒ B 703571.0 - Chapter 13.12 "Process screen", page 152

5 Operation

Some of the levels in the device menu are username- and password-protected. The level protection is defined in the user list by the setup program, using five different users. On entering the password, each user is entitled to use the "rights" available.

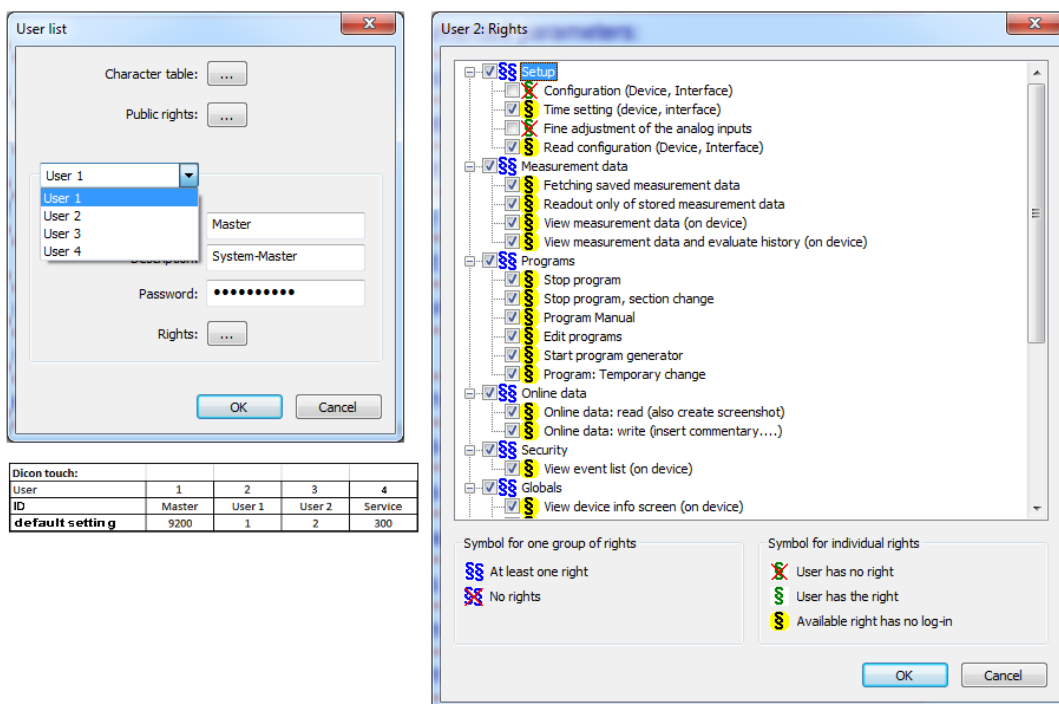

Dicon touch:	1	2	3	4
User	Master	User 1	User 2	Service
default setting	9200	1	2	300

If permitted, the rights and passwords can also be changed on the device.

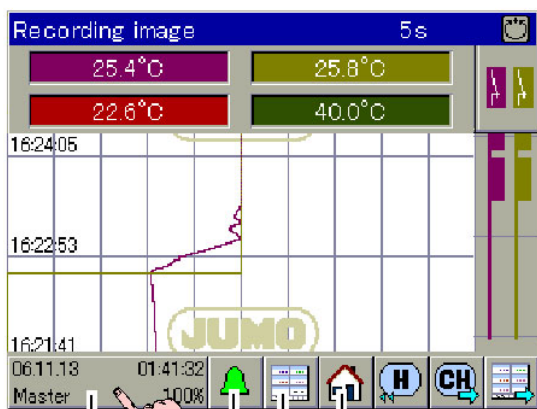

2 function buttons
Alarm- and eventlist
Device settings menu

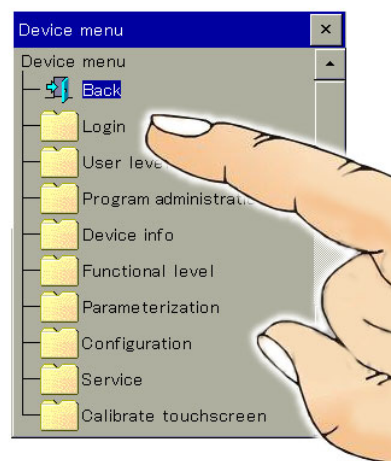

Touching the screen in the bottom left-hand corner opens the device menu window. Touching the 'Login' function opens the Login window.

6 Login

6.1 Logging on

This sequence shows the logon process as the master user (with the default password 9200):

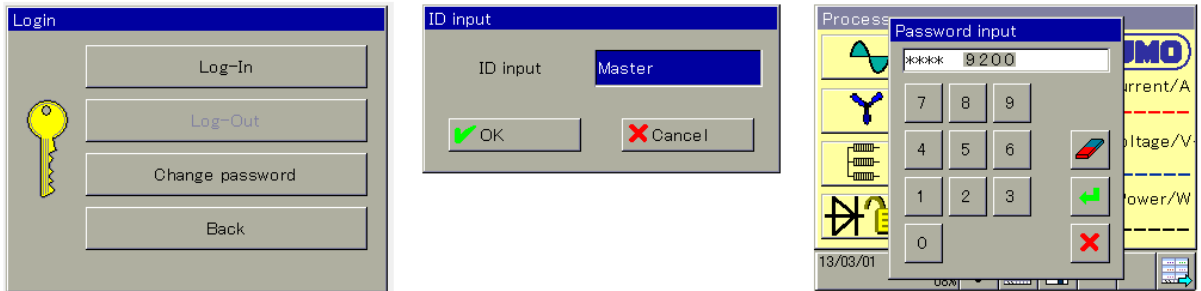

User 1 is now logged on and is permitted to access all functions listed under "Rights".

6.2 Logging out

As soon as you are logged on, the Log-Out button is no longer grayed out and touching it will enable you to log out. Consequently, your user rights will be limited.

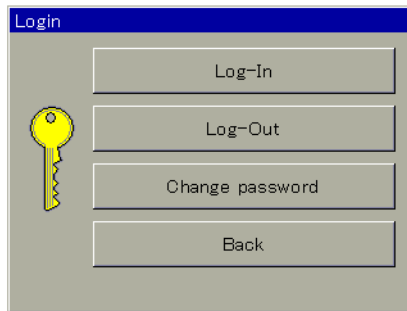

6.3 Changing the password

You can change the user password that you are currently logged in with here. To do this, you must first enter the old password (for the master user) and then the new one. If the password is incorrect, the change will not be accepted.



7.1 Enter program curves

Ten programs can be entered on the device or in the setup program.

7.1.1 On the device

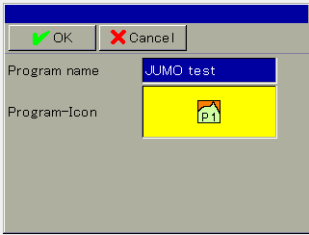
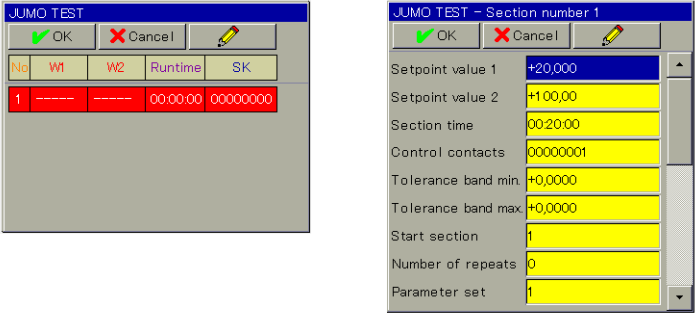
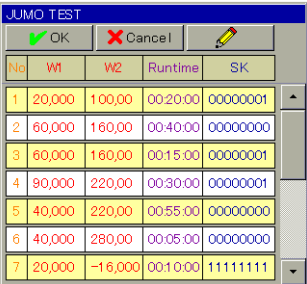
Step	Activity																																								
1	<p>Enter program names and icons</p> 																																								
2	<p>Enter first section: If the program memory is empty, the section will be highlighted in red.</p>  <p>Each section consists of: target values 1 and 2, section time, control contacts, tolerance band, number of repetitions from start section, and parameter block.</p>																																								
3	<p>Repeat section entries until the table is complete</p>  <table border="1" data-bbox="767 1406 1075 1688"> <thead> <tr> <th>No</th> <th>W1</th> <th>W2</th> <th>Runtime</th> <th>SK</th> </tr> </thead> <tbody> <tr> <td>1</td> <td>20,000</td> <td>100,00</td> <td>00:20:00</td> <td>00000001</td> </tr> <tr> <td>2</td> <td>60,000</td> <td>160,00</td> <td>00:40:00</td> <td>00000000</td> </tr> <tr> <td>3</td> <td>60,000</td> <td>160,00</td> <td>00:15:00</td> <td>00000001</td> </tr> <tr> <td>4</td> <td>90,000</td> <td>220,00</td> <td>00:30:00</td> <td>00000001</td> </tr> <tr> <td>5</td> <td>40,000</td> <td>220,00</td> <td>00:55:00</td> <td>00000000</td> </tr> <tr> <td>6</td> <td>40,000</td> <td>280,00</td> <td>00:05:00</td> <td>00000000</td> </tr> <tr> <td>7</td> <td>20,000</td> <td>-16,000</td> <td>00:10:00</td> <td>11111111</td> </tr> </tbody> </table>	No	W1	W2	Runtime	SK	1	20,000	100,00	00:20:00	00000001	2	60,000	160,00	00:40:00	00000000	3	60,000	160,00	00:15:00	00000001	4	90,000	220,00	00:30:00	00000001	5	40,000	220,00	00:55:00	00000000	6	40,000	280,00	00:05:00	00000000	7	20,000	-16,000	00:10:00	11111111
No	W1	W2	Runtime	SK																																					
1	20,000	100,00	00:20:00	00000001																																					
2	60,000	160,00	00:40:00	00000000																																					
3	60,000	160,00	00:15:00	00000001																																					
4	90,000	220,00	00:30:00	00000001																																					
5	40,000	220,00	00:55:00	00000000																																					
6	40,000	280,00	00:05:00	00000000																																					
7	20,000	-16,000	00:10:00	11111111																																					
4	<p>Touching the pencil symbol enables additional editing functions.</p> <ul style="list-style-type: none"> • Editing the program header • Copying and deleting the program • Creating a new section 																																								

- ➔ Two program curves have now been programmed.
They can be started at any section at an adjustable time and run in parallel.

7 Program administration

7.1.2 About the setup program

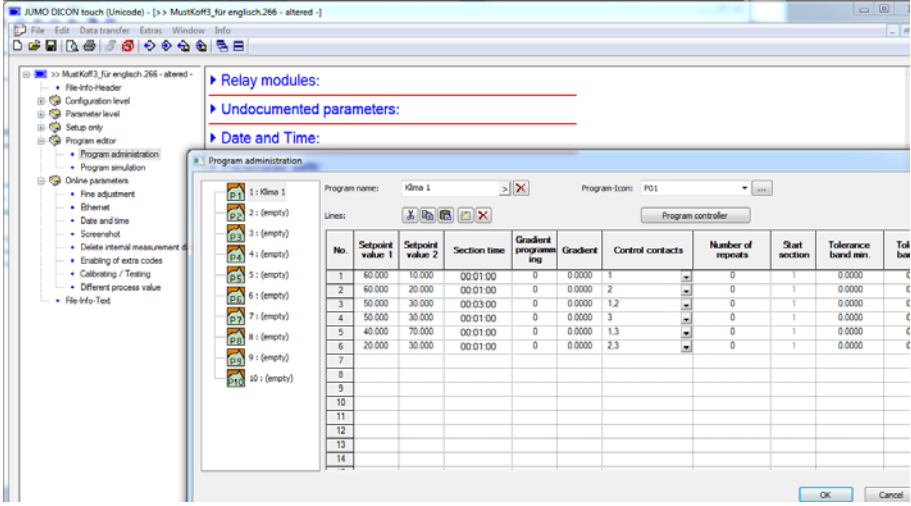
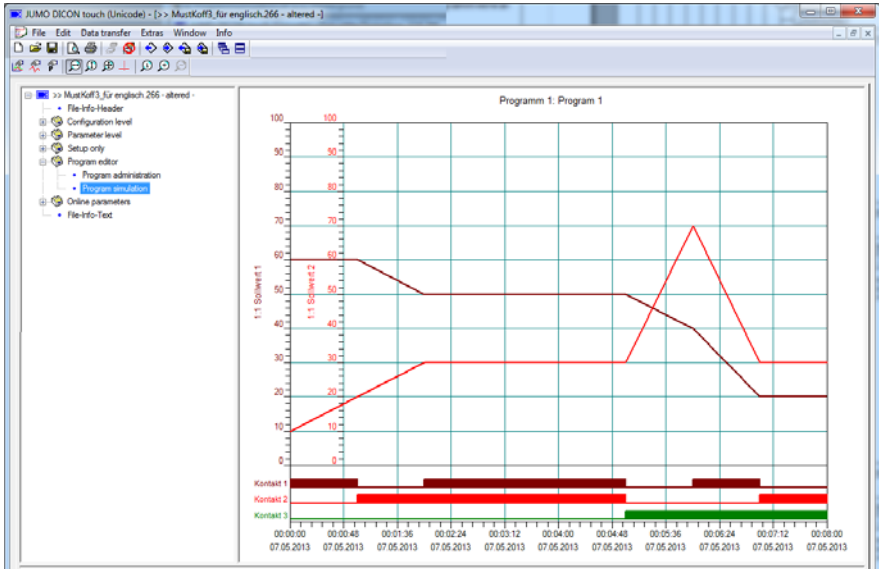
Step	Activity
1	<p>Start the setup program and click on Program editor > Program administration in the menu</p> 
2	<p>Enter sections in the table</p>
3	<p>The table is displayed as a graphic with the program simulation</p> 

7 Program administration

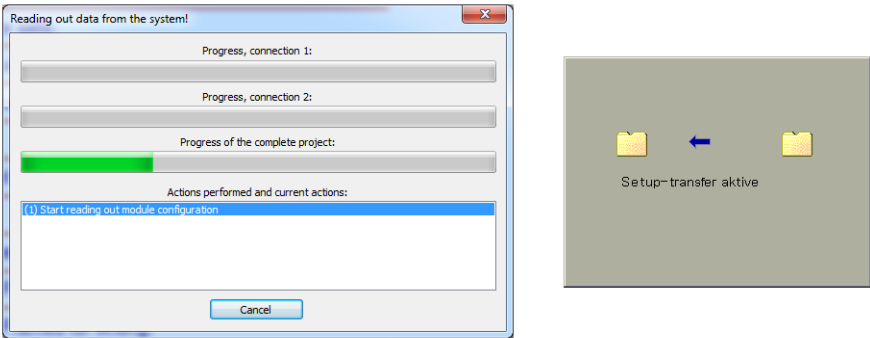
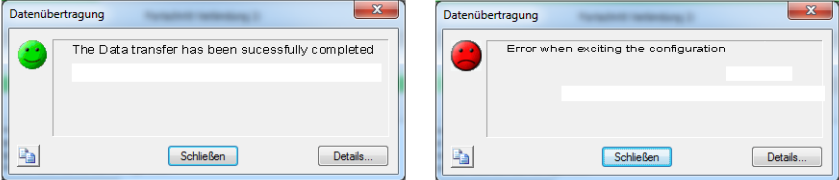
Step	Activity
4	<p>Save the setup file and transfer the setup data to the device</p> 
5	<p>If a green icon (smiley) appears, then the programs have been successfully transferred.</p> 

➔ Two program curves are now saved in the device and can be started at any section at an adjustable time and run in parallel.

7.1.3 Section run time

The period of time between sections.

Setpoint values varying from section to section create a ramp-like setpoint curve (with a negative or positive slope).

7.1.4 Setpoint values 1 and 2

Each program contains 2 setpoint value profiles which can be used to create 2 program controllers.

7.1.5 Control contacts

Eight control contacts can be set at any one time. They are available in the digital selector and can switch on relays, for instance.

⇒ Setup program:

CONFIGURATION LEVEL > DIGITAL OUTPUTS

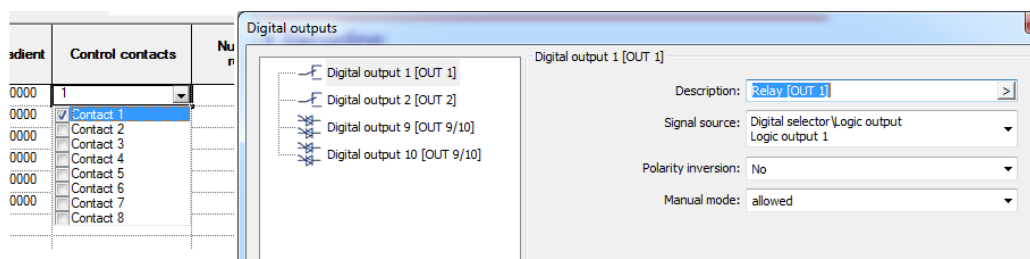

They can also be logically linked or can initiate internal device functions.

7 Program administration

7.1.6 Tolerance band

⇒ B 703571.0 - Chapter 12.6.7 "Ramp function", page 95

7.1.7 Number of repetitions

The number of repetitions is entered for a specific start section.

7.1.8 Start section

Repetition begins from this section.

Example

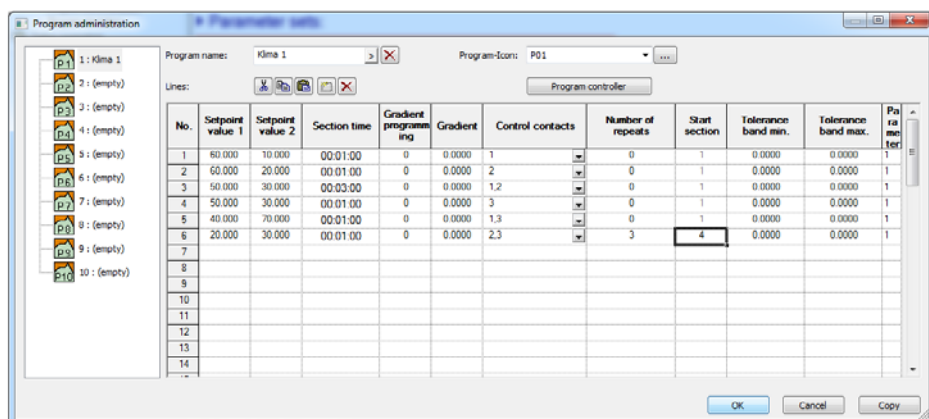

The screenshot shows the 'Program administration' window with a table of program lines. The table has columns for 'No.', 'Setpoint value 1', 'Setpoint value 2', 'Section time', 'Gradient programming', 'Gradient', 'Control contacts', 'Number of repeats', 'Start section', 'Tolerance band min.', 'Tolerance band max.', and 'Parameter'. Line 6 is highlighted, showing 3 repetitions starting from section 4.

No.	Setpoint value 1	Setpoint value 2	Section time	Gradient programming	Gradient	Control contacts	Number of repeats	Start section	Tolerance band min.	Tolerance band max.	Parameter
1	60.000	10.000	00:01:00	0	0.0000	1	0	1	0.0000	0.0000	1
2	60.000	20.000	00:01:00	0	0.0000	2	0	1	0.0000	0.0000	1
3	50.000	30.000	00:03:00	0	0.0000	1,2	0	1	0.0000	0.0000	1
4	50.000	30.000	00:01:00	0	0.0000	3	0	1	0.0000	0.0000	1
5	40.000	70.000	00:01:00	0	0.0000	1,3	0	1	0.0000	0.0000	1
6	20.000	30.000	00:01:00	0	0.0000	2,3	3	4	0.0000	0.0000	1
7											
8											
9											
10											
11											
12											
13											
14											
--											

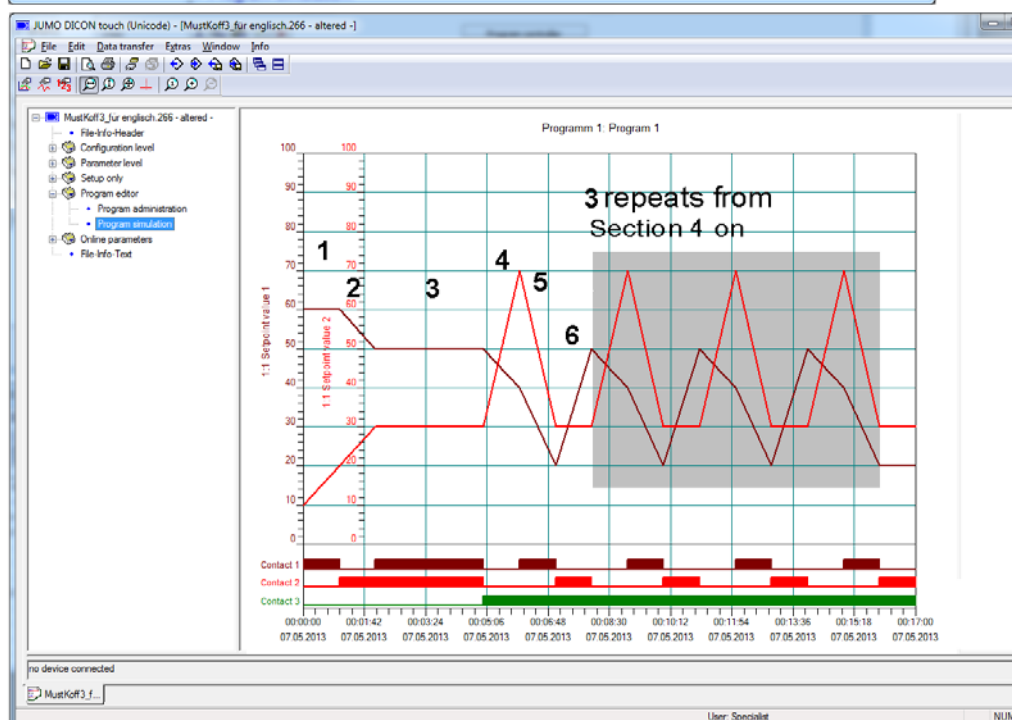

7.1.9 Parameter block

For each controller channel, parameter blocks 1 to 4 are available and can be switched in any combination



NOTE!

The parameters described in this section can be entered either in the setup program or in DI-CON touch. This is where the parameters that are directly linked to the alignment of the controller with the control path are set, after the system has been commissioned.

You must be logged in to change the parameters.

- ⇒ Device menu section > Login
- ⇒ Chapter 7 "User level (Log-In)", page 45

Setup dialog

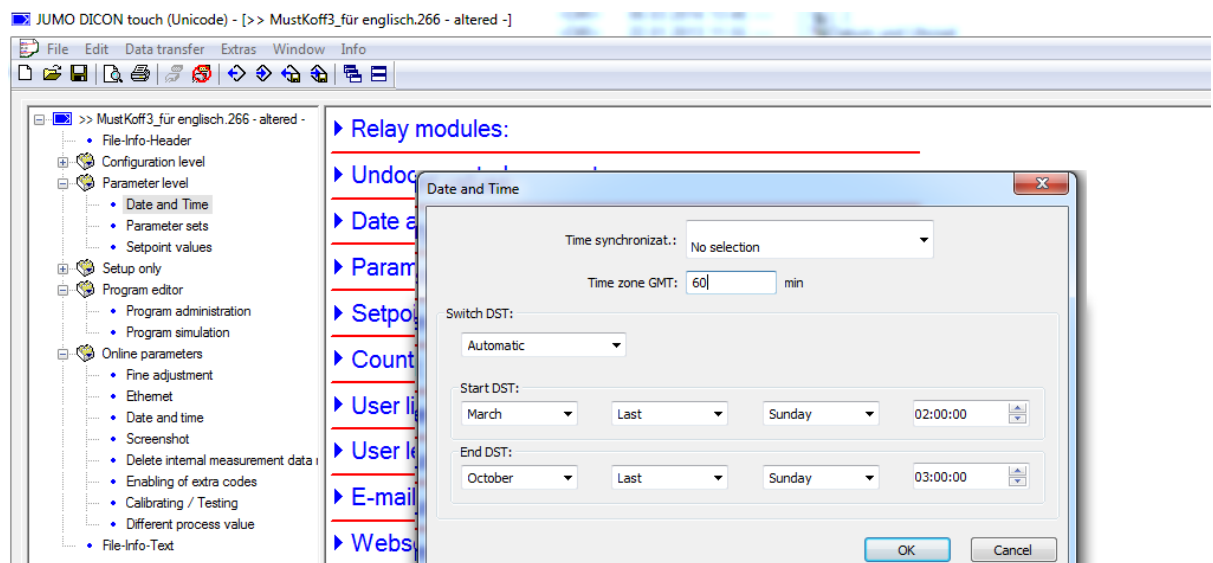

8.1 Date and time

The following table shows the time settings for the device.

Parameter	Setting	Description
Current date	2011/01/01 2083/12/31	Enter the date here.
Current time	00:00:00 23:59:59	Enter the time here.

8.2 Daylight saving time

The following table shows the settings for daylight saving time.

Parameter	Setting	Description
Synchronization	No function Digital selector	A digital signal can be selected here to synchronize the time.
Switch daylight saving time	Automatic Inactive	Enables you to set the time to change automatically.

8 Parameterization

Parameter	Setting	Description
Start DST	Month: March Week: last week Day: Sunday Time: 02:00:00	
End DST	Month: October Week: last week Day: Sunday Time: 03:00:00	

8.3 Controller/parameter blocks

Setup dialog

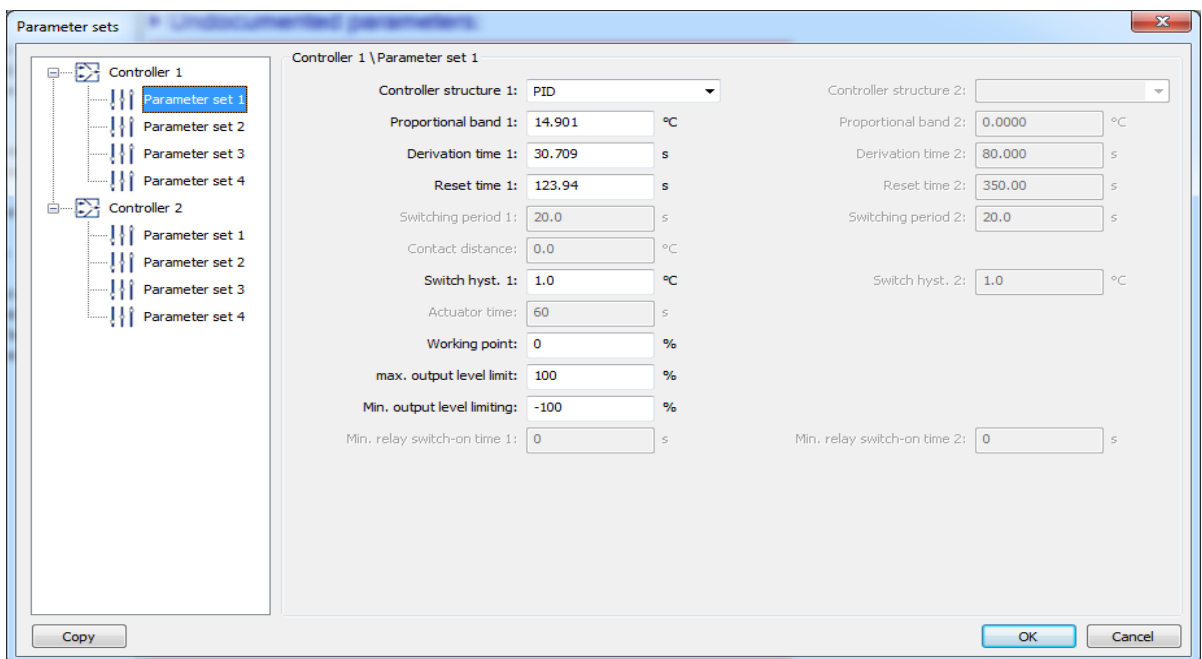

The following table shows the parameters in a parameter block. These parameters are also available for the other three parameter blocks. Four parameter blocks can be defined for each of the two controller channels. Switching the parameter blocks is performed separately for each controller channel via two digital signals.

Depending on the controller type configured, certain parameters may be omitted or ineffective. Parameters that appear in pairs such as Proportional band 1 and 2 refer to the first and second controller outputs (for instance, with three-state controllers).

The parameter blocks are assigned to both controllers in the configuration level.

⇒ B 703571.0 - Chapter 12.6.2 "Controller inputs", page 80

8 Parameterization

Parameter	Setting	Description
Proportional band 1 (Xp1)	0 ... 9999	Value for the proportional band The controller structure has no effect if $X_p = 0$ (behavior identical to limit value monitoring)! For a continuous controller, X_p must be > 0 .
Proportional band 2 (Xp2)	0 ... 9999	
Derivative time 1 (Tv1)	0 ... 80 ... 9999 s	The derivative time influences the differential component (D component) of the controller output signal. The greater the derivative time, the more effect the D component has.
Derivative time 2 (Tv2)	0 ... 80 ... 9999 s	
Reset time 1 (Tn1)	0 ... 350 ... 9999 s	The reset time influences the integral component (I component) of the controller output signal. The greater the reset time, the less effect the I component has.
Reset time 2 (Tn2)	0 ... 350 ... 9999 s	
Cycle time 1 (Cy1)	0 ... 20 ... 999.9 s	When using a switched output, the cycle time should be chosen so that the energy supply to the process is as continuous as possible without overloading the switching elements.
Cycle time 2 (Cy2)	0 ... 20 ... 999.9 s	
Contact spacing (Xsh)	0 ... 999.9	Spacing between the two control contacts for a three-state controller, modulating controller, and continuous controller with integrated position controller
Switching differential 1 (Xd1)	0 ... 1 ... 999.9	Hysteresis for a switching controller with proportional band $X_p = 0$
Switching differential 2 (Xd2)	0 ... 1 ... 999.9	
Actuator time (TT)	5 ... 60 ... 3000 s	Control valve running time range used for a modulating controller and continuous controller with integrated position controller
Working point (Y0)	-100 to 0 to +100 %	Working point correction for a P or PD controller (correction value for the output level) If the actual value (x) has reached the setpoint value (w), the output level (y) corresponds to the working point (Y0).
Max. output level limit (Y1)	0 to 100 %	Admissible maximum output level (only effective if $X_p > 0$)

8 Parameterization

Parameter	Setting	Description
Min. output level limit (Y2)	-100 to +100 %	Admissible minimum output level (only effective if $X_p > 0$)
Minimum relay ON period 1 (Tk1)	0 to 60 s	Limits the frequency of switching for switched outputs
Minimum relay ON period 2 (Tk2)	0 to 60 s	

Transmission behavior

The transmission behavior (controller structure) is determined by the configuration of the parameters for the proportion band (P component), derivative time (D component), and reset time (I component).

Two-state controller

This controller has a switched output and can be parameterized with P, PI, PD, or PID transmission behavior. The proportional band X_p must be greater than 0 for the controller structure to take effect.

If $X_p = 0$, the behavior corresponds to the function of limit value monitoring with switching differential X_{d1} (working point $Y_0 = 0\%$):

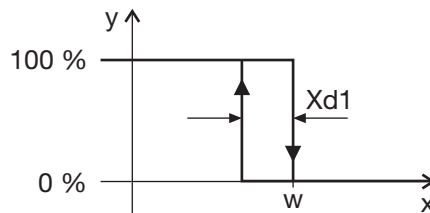

Influence of working point Y_0 on the switching behavior

$Y_0 = 0\%$

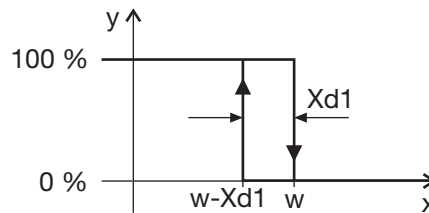

$Y_0 = 100\%$

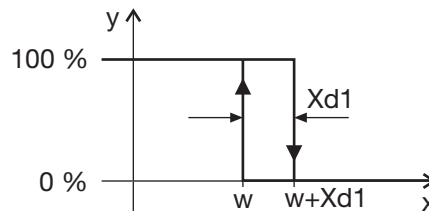

$Y_0 = -100\%$

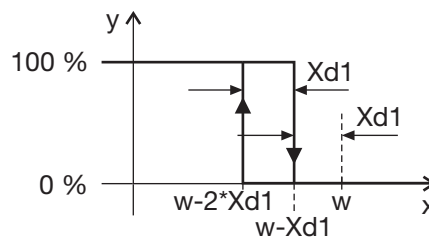

8 Parameterization

Three-state controller

This controller has two outputs, which can be configured as continuous (analog output) or switched (digital output). In both cases, the controller can be parameterized with P, PI, PD, or PID transmission behavior. The proportional bands $Xp1$ and $Xp2$ must be greater than 0 for the controller structure to take effect.

If $Xp1 = 0$ and $Xp2 = 0$, the behavior corresponds to the function of limit value monitoring with switching differential $Xd1$ and $Xd2$, and contact spacing Xsh (working point $Y0 = 0\%$):

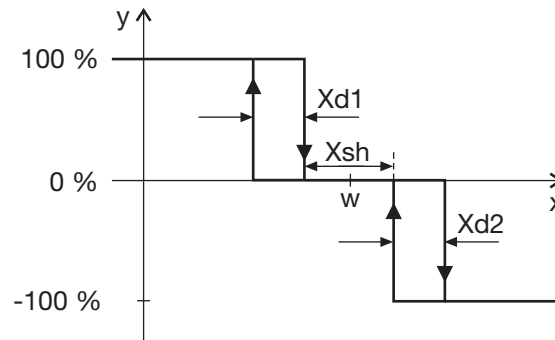

Modulating controller

This controller has two switched outputs and can be parameterized with PI or PID transmission behavior. The proportional band Xp must be greater than 0 for the controller structure to take effect.

The modulating controller is used for actuator drives with three switching statuses (actuator open, closed, hold). If output level feedback is available, the active output is deactivated when the output level limits are reached.

Continuous controller

This controller has a continuous output (analog output) and can be parameterized with P, PI, PD, or PID transmission behavior. The proportional band Xp must be greater than 0 for the controller structure to take effect (the setting $Xp = 0$ is normally used in practice).

Position controller

This controller is a continuous controller with integrated position controller and two switched outputs (digital outputs) with PI or PID transmission behavior.

The position controller is used for actuator drives with three switching statuses (actuator open, closed, hold). An output level feedback is required.

8.4 Setpoint values

Four switchable setpoint values are assigned to a fixed-setpoint controller and can be entered on the device or in the setup program.

The following table shows the setpoint changeover for fixed-setpoint controllers using two digital signals that can be Chapter 12.6.6 "Controller setpoint values", page 93 set.

For program controllers

⇒ Chapter 7.1 "Enter program curves", page 43

8 Parameterization

Type	Signal 2 (Bit 1) setpoint changeover	Signal 1 (Bit 0) setpoint changeover	Setpoint value, Controller 1	Setpoint value, Controller 2
Fixed-setpoint controller	0	0	Setpoint value 1	Setpoint 1
	0	1	Setpoint value 2	Setpoint value 2
	1	0	Setpoint value 3	Setpoint value 3
	1	1	Setpoint value 4	Setpoint value 4
Program controller			W1 and W2 are predefined by the program generator	

8.4.1 Entered on the device

The setpoint values in the parameter level are entered on the device.

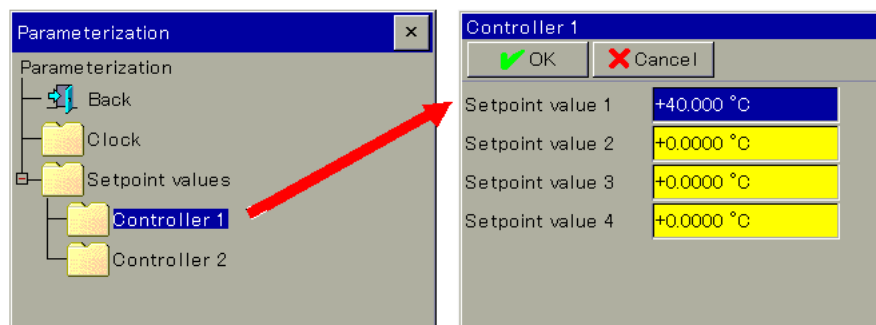

8.4.2 Entered using the setup program

The setpoint values are entered in the setup dialog parameter level.

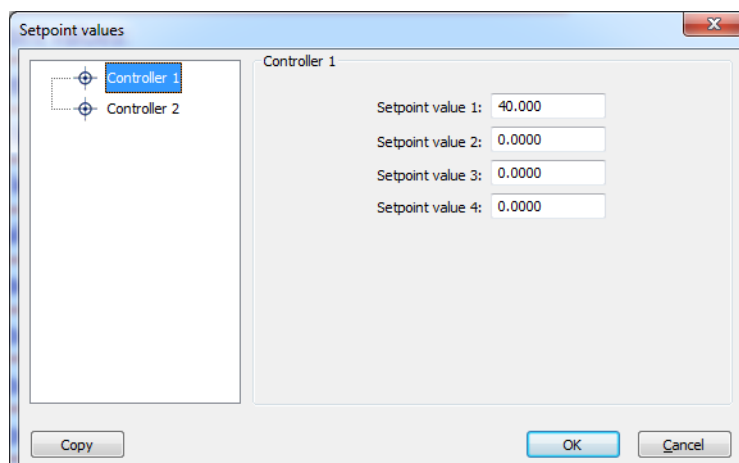

8 Parameterization



NOTE!

The parameters described in this section can be edited using either the setup program or DICON touch. A detailed description of the parameters you can find in the operating manual B70.3571.0.

Depending on the configuration, signals which are not in use are grayed out. Functions available in both selectors are highlighted in a specific color.

9.1 Analog selector

- Analog selection
- No selection
- Analog inputs
- External analog input
- Mathematics
- Controller
- Setpoint values
- Program setpoint val.
- Section end values
- Flag
- Service
- Sampling periode

The analog selector contains all analog signals available in the configuration dialogs of a tree structure in the DICON touch.

All analog signals are shown in the following table. The entry in the "Type" column indicates the source of the signal:

- Internal: Internal signal for the DICON touch (including signals from the analog inputs)
- External: External input, for example, one that can be transmitted via an interface

Category	Signal	Type	Description
No function			No signal selected
Analog inputs	Analog input (IN8) Analog input (IN9) Analog input (IN10) Analog input (IN11)	Internal	Measured values for analog inputs 1 to 4 ⇒ Siehe 609.5 Example to set Analog inputs IN8, IN9, IN10, IN11
External analog inputs	External analog inputs 1 to 8	External	Analog value for the external analog input 1 to 8 ⇒ Siehe 13512.18 External analog inputs
Mathematics	Mathematics 1 to 8	Internal	Result of mathematical function 1 to 8 ⇒ Siehe 13012.15 Mathematics/logic
Controller 1	Actual value for Controller 1 Setpoint value, Controller 1 Controller differential, Controller 1 Output level display, Controller 1 Output 1, Controller 1 Output 2, Controller 1 Cascade output level, Controller 1	Internal	⇒ Siehe 7712.6.1 Controller configuration
Controller 2	Actual value, Controller 2 Setpoint value, Controller 2 Controller differential, Controller 2 Output level display, Controller 2 Output 1, Controller 2 Output 2, Controller 2 Cascade output level, Controller 2		

9 Configuration

Category	Signal	Type	Description
Setpoint values	Ramp end value, Controller 1 Setpoint specification, Controller 1 Setpoint value 1 to 4, Controller 1 Ramp end value, Controller 2 Setpoint specification, Controller 2 Setpoint value 1 to 4, Controller 2	Internal	Setpoint value for controller channel 1 to 2 as fixed setpoint controller ⇒ Siehe 9312.6.6 Controller setpoint values
Program setpoint	Program setpoint 1, 2	Internal	Setpoint value for controller channel 1 to 2 as program controller ⇒ Siehe 11612.12 Program controller
Section end values	Section end value 1 to 2	Internal	
Flags	Flags 1 to 8	Internal	Analog value of the analog flag ⇒ Siehe 13212.16 Flags/service
Service	Terminal temperature	Internal	Measured value (internal Pt100)
Sampling rate	Sampling rate	Internal	Measured value, sampling rate

9.2 Digital selector

- Digital selector
- No selection
- + Controller
- + Digital inputs
- + External digital inputs
- + Digital control signals
- + Limit value outputs
- + Timer
- + Logic output
- + Ramp signals
- + Program controller
- + Control contacts

The digital selector contains all digital signals that are available in the configuration dialogs of a tree structure in the DICON touch.

All the digital signals are shown in the following table. The entry in the "Type" column indicates the source of the signal:

- Internal: Internal signal for the DICON touch (including digital input signals)
- External: External value is transferred via the interface, for example

Category	Signal	Type	Description
No function			No signal selected
Controller 1	1st output, Controller 1	Internal	Switching outputs, Controller 1 Logic level "0", function inactive Logic level "1", function inactive ⇒ Siehe 7712.6.1 Controller configuration
	2nd output, Controller 1		
	Self-optimization, Controller 1		
	Manual mode, Controller 1		
	Controller 1, off		
	Controller cycle alarm 1		
Controller 2	1st output, Controller 2	Internal	Switching outputs, Controller 2 Logic level "0", function inactive Logic level "1", function inactive ⇒ Siehe 7712.6.1 Controller configuration
	2nd output, Controller 2		
	Self-optimization, Controller 2		
	Manual mode, Controller 2		
	Controller 2, off		
	Controller cycle alarm 2		
	Output level alarm 2		

9 Configuration

Category	Signal	Type	Description
Digital inputs	Digital input 1 to 7	Internal	Logic level for connected floating contacts 1 to 7 ⇒ Siehe 7212.4Digital inputs IN1 to 7
External digital inputs	External digital input 1 to 8	External	Logic level for the external digital inputs 1 to 8 ⇒ Siehe 13412.17External digital inputs
Digital controller signals	Digital controller signals 1 to 8	Internal	Logic level for the defined digital controller signals 1 to 8 ⇒ Siehe 12612.14Digital controller signals
Limit value outputs	Limit value output 1 to 16	Internal	Logic level of the limit value monitoring 1 to 16 ⇒ Siehe 10012.9Limit value monitoring
Timer	Timer output 1 Timerendsignal 1 Timertoleranceband 1 Timerstoppsignal 1 Timeroutput 2 Timerendsignal 2 Timertoleranceband 2 Timerstoppsignal 2	Internal	Logic level of the output signals for Timer 1, 2 Logic level "0", function inactive Logic level "1", function inactive ⇒ Siehe 12412.13Timer or time switch
Logic output	Logic output 1 to 8	Internal	Result of logic function 1 to 8 ⇒ Siehe 13012.15Mathematics/logic
Ramp signals	Rampendsignal 1 Tolerancebandsignal 1 Rampendsignal 2 Tolerancebandsignal 2	Internal	Logic level "0", function inactive Logic level "1", function inactive ⇒ Siehe 9512.6.7Ramp function
Program controller	Program end signal Programautosignal Tolerancebandsignal Programstoppsignal	Internal	Logic level "0", function inactive Logic level "1", function inactive ⇒ Siehe 11612.12Program controller
Control contacts	Control contacts 1 to 8	Internal	Logic level of the control contacts, for example in automatic mode. ⇒ Siehe 457.1.5Control contacts
Flags	Digital flags 1 to 8	Internal	Logic level of the digital flag ⇒ Siehe 13212.16Flags/service
Service	Service signal	Internal	Logic level of the service signal ⇒ Siehe 13212.16Flags/service

9 Configuration

Category	Signal	Type	Description
Function buttons	Function button 1 to 2	Internal	Logic level of the two function buttons ⇒ Siehe 335.1 Display and operating concept
Analog input alarm	MinAlarm IN8 MaxAlarm IN8 MinAlarm IN9 MaxAlarm IN9 MinAlarm IN10 MaxAlarm IN10 MinAlarm IN11 MaxAlarm IN11	Internal	Min and max alarm signals of the analog inputs 1 to 4 ⇒ Siehe 609.5 Example to set Analog inputs IN8, IN9, IN10, IN11
Ext. analog entry alarm	MinAlarm Ext. AE 1 MaxAlarm Ext. AE 1 MinAlarm Ext. AE 2 MaxAlarm Ext. AE 2 MinAlarm Ext. AE 3 MaxAlarm Ext. AE 3 MinAlarm Ext. AE 4 MaxAlarm Ext. AE 4 MinAlarm Ext. AE 5 MaxAlarm Ext. AE 5 MinAlarm Ext. AE 6 MaxAlarm Ext. AE 6 MinAlarm Ext. AE 7 MaxAlarm Ext. AE 7 MinAlarm Ext. AE 8 MaxAlarm Ext. AE 8	Internal	Min and max alarm signals for the ext. analog inputs 1 to 8 ⇒ Siehe 13512.18 External analog inputs
Math alarm	MinAlarm Math 1 MaxAlarm Math 1 MinAlarm Math 2 MaxAlarm Math 2 MinAlarm Math 3 MaxAlarm Math 3 MinAlarm Math 4 MaxAlarm Math 4 MinAlarm Math 5 MaxAlarm Math 5 MinAlarm Math 6 MaxAlarm Math 6 MinAlarm Math 7 MaxAlarm Math 7 MinAlarm Math 8 MaxAlarm Math 8	Internal	⇒ Siehe 13012.15 Mathematics/logic

9 Configuration

Category	Signal	Type	Description
Digital alarms	Digital alarm 1 to 7	Internal	Alarms for connected floating contacts 1 to 7 ⇒ Siehe 7212.4Digital inputs IN1 to 7
Ext. digital alarms	Ext. digital alarm 1 to 8	External	Alarms for ext. digital inputs ⇒ Siehe 13412.17External digital inputs
Digital control alarms	Digital control alarm 1 to 8	Internal	Alarms for the defined digital controller signals 1 to 8 ⇒ Siehe 12612.14Digital controller signals
Limit value alarms	Limit value alarm 1 to 16	Internal	Alarms for the limit value monitoring 1 to 16 ⇒ Siehe 10012.9Limit value monitoring
Logic alarms	Logic alarms 1 to 8	Internal	Alarms for logic function 1 to 8 ⇒ Siehe 13012.15Mathematics/logic
Alarms and internal signals	Collective alarm	Internal	Collective alarm for the controller
	Collective alarm acknowledged		
	Memory alarm		Memory alarm limit exceeded ⇒ Siehe 609.4Example basic settings
	Fault		
	Field bus error		
	Battery empty		Back-up battery must be replaced
	Pre-alarm battery		Back-up battery voltage under 2.6 V
	Login		Logic level "0", user not logged on Logic level "1", user logged on
	USB inserted		Logic level "0" USB not inserted Logic level "1", USB inserted
	Temp. in Fahrenheit		Logic level "0", temp. not °F Logic level "1", temp. in °F
	Inside temperature too high	Logic level "0", inside temperature not too high Logic level "1", inside temperature too high	

9 Configuration

9.3 General information

This examples show how to set parameters in the configuration level via device.
A detailed description of all the parameters you can find in the operating manual B70.3571.0 on the internet or on the setup program-CD..

9.4 Example basic settings

This is the way to go to the menu „basic settings“:

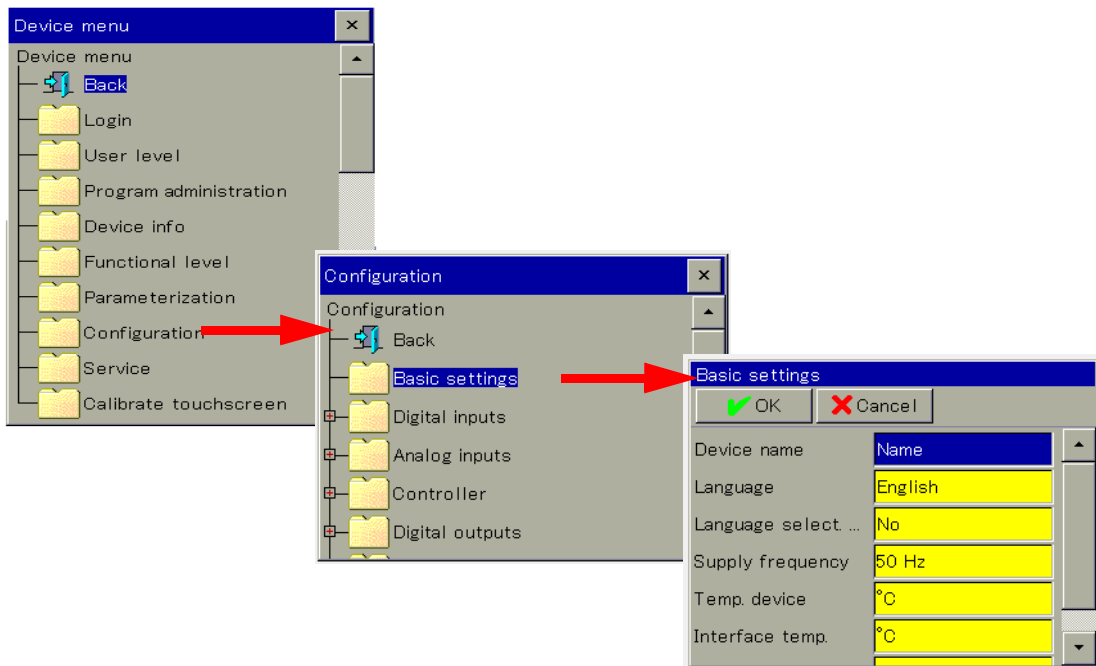

9.5 Example to set Analog inputs IN8, IN9, IN10, IN11

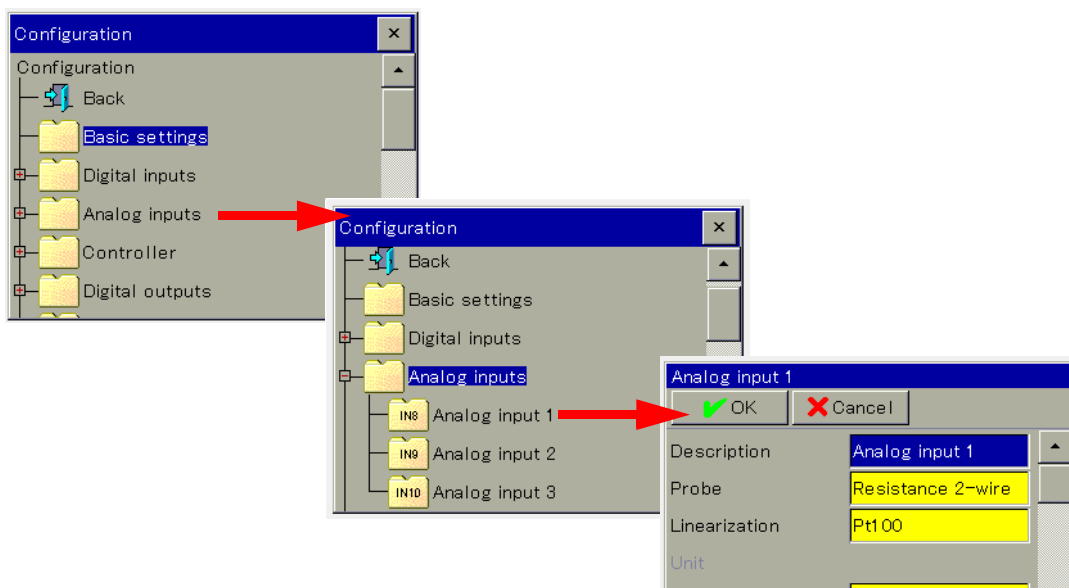

10.1 Calibrating the touchscreen

The display on the TFT screen may no longer correspond to the points of contact on the adhesive touchscreen cover.

In this case, the touchscreen must be calibrated.

DEVICE MENU>CALIBRATE TOUCHSCREEN

To do this, four interchangeable screen points must be treated as accurately as possible with a pen wherever an 'x' appears.

The device saves these coordinates and this enables the assignment of the TFT screen and the touchscreen to correspond again.

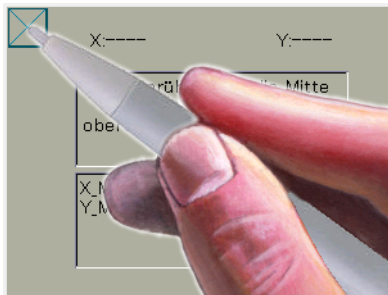

10 Special functions

11.1 Error messages in float values and on the display

The display is shown as a float value itself. The following statuses are defined.

Error	Float value display	Display
First error value	1.0E+37	
Software – underrange	1.0E+37	<<<<<<
Software – overrange	2.0E+37	>>>>>>
No valid input value	3.0E+37	-----
Division by zero	4.0E+37	-----
Incorrect mathematical value	5.0E+37	-----
Display capacity exceeded		*****
Invalid value		-----

In the event of an error, the device function reports this error itself in its output value. All device functions monitor an input value for these error values. In the event of an error, the output value is applied in turn to one of these error values, or another value is specified in the configuration (error value/substitute value).

11.2 Display of error messages for binary values

Binary input values are only displayed with 0 and 1. If no valid input value is available, or the device function cannot deliver a valid output value, the value is set to 0.

Exception

In the configuration level you can set which value the output should accept in the event of an error (error value/substitute value) and this value is then faded in.

Start/end display:

The graphic display elements of the display range are established for this (lower and upper limit in a bar graph display). The numeric representation is dependent on the display start/end and is produced from the entire measuring range. In the recording, measured values smaller than the display start are saved as UNDERRANGE and measured values larger than the display end are saved as OVERRANGE.

Bar graph display:

The numeric representation is dependent on the display start/end and is produced from the entire measuring range. In the recording, measured values smaller than the display start are saved as UNDERRANGE and measured values larger than the display end are saved as OVERRANGE.

Over- and underrange:

Detection is performed at hardware limits and on the scaling in mV. The maximum number of display ranges are therefore always available. For all the values calculated in the device such as mathematics output, flow rate, and external inputs, the following applies: The display range has the same significance here as for hardware inputs.

11 Error and alarm messages

12.1 China RoHS

部件名称 Product group: 703571	有毒有害物质或元素 Hazardous substances					
	铅 (Pb)	汞 (Hg)	镉 (Cd)	六价铬 (Cr(VI))	多溴联苯 (PBB)	多溴二苯醚 (PBDE)
外壳 Housing (Gehäuse)	X	○	○	○	○	○
过程连接 Process connection (Prozessanschluss)	○	○	○	○	○	○
螺母 Nut (Mutter)	○	○	○	○	○	○
螺钉 Screw (Schraube)	○	○	○	○	○	○

本表格依据 SJ/T 11364-2014 的规定编制。
 (This table is prepared in accordance with the provisions of SJ/T 11364-2014.)
 ○ : 表示该有害物质在该部件所有均质材料中的含量均在 GB/T 26572 规定的限量要求以下。
 (O: Indicates that said hazardous substance contained in all of the homogeneous materials for this part is below the limit requirement of GB/T 26572.)
 X : 表示该有害物质至少在该部件的某一均质材料中的含量超出 GB/T 26572 规定的限量要求。
 (X: Indicates that said hazardous substance contained in one of the homogeneous materials used for this part is above the limit requirement of GB/T 26572.)



JUMO GmbH & Co. KG

Street address:
Moritz-Juchheim-Straße 1
36039 Fulda, Germany
Delivery address:
Mackenrodtstraße 14
36039 Fulda, Germany
Postal address:
36035 Fulda, Germany
Phone: +49 661 6003-0
Fax: +49 661 6003-607
Email: mail@jumo.net
Internet: www.jumo.net

JUMO Instrument Co. Ltd.

JUMO House
Temple Bank, Riverway
Harlow, Essex CM 20 2DY, UK
Phone: +44 1279 63 55 33
Fax: +44 1279 62 50 29
Email: sales@jumo.co.uk
Internet: www.jumo.co.uk

JUMO Process Control, Inc.

6733 Myers Road
East Syracuse, NY 13057, USA
Phone: +1 315 437 5866
Fax: +1 315 437 5860
Email: info.us@jumo.net
Internet: www.jumousa.com

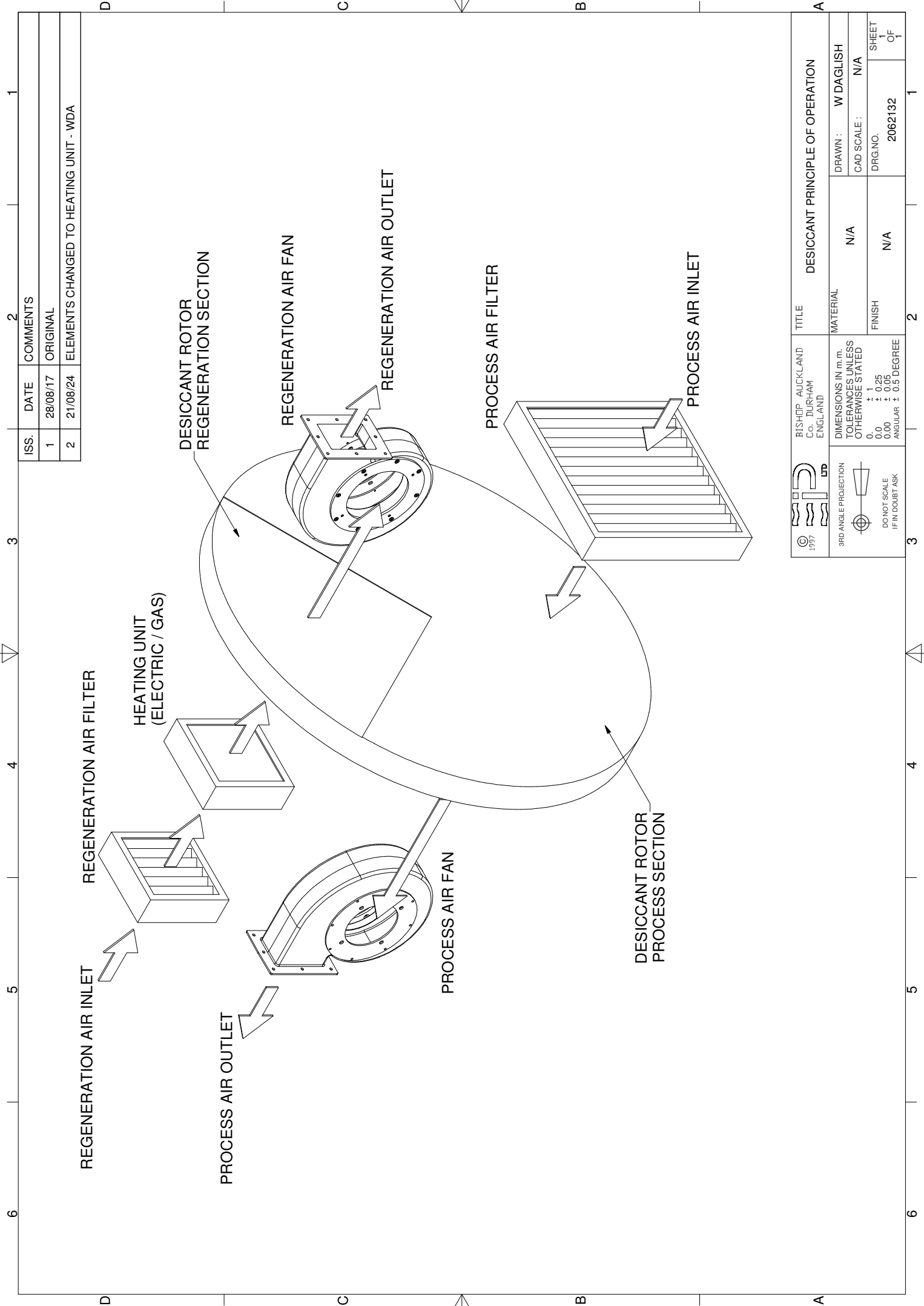

ISS.	DATE	COMMENTS
1	28/08/17	ORIGINAL
2	21/08/24	ELEMENTS CHANGED TO HEATING UNIT - WDA

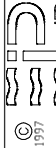
BISHOP AUCKLAND CO. DURHAM ENGLAND		DESICCANT PRINCIPLE OF OPERATION	
 3RD ANGLE PROJECTION DO NOT SCALE IF IN DOUBT/ASK	DIMENSIONS IN m.m. TOLERANCES UNLESS OTHERWISE STATED 0.0 ± 1 0.00 ± 0.25 0.00 ± 0.05 ANGULAR ± 0.5 DEGREE	MATERIAL	N/A
		FINISH	N/A
		DRAWN :	W DAGLISH
		CAD SCALE :	N/A
		DRG.NO.	2062132
		SHEET	1 OF 1

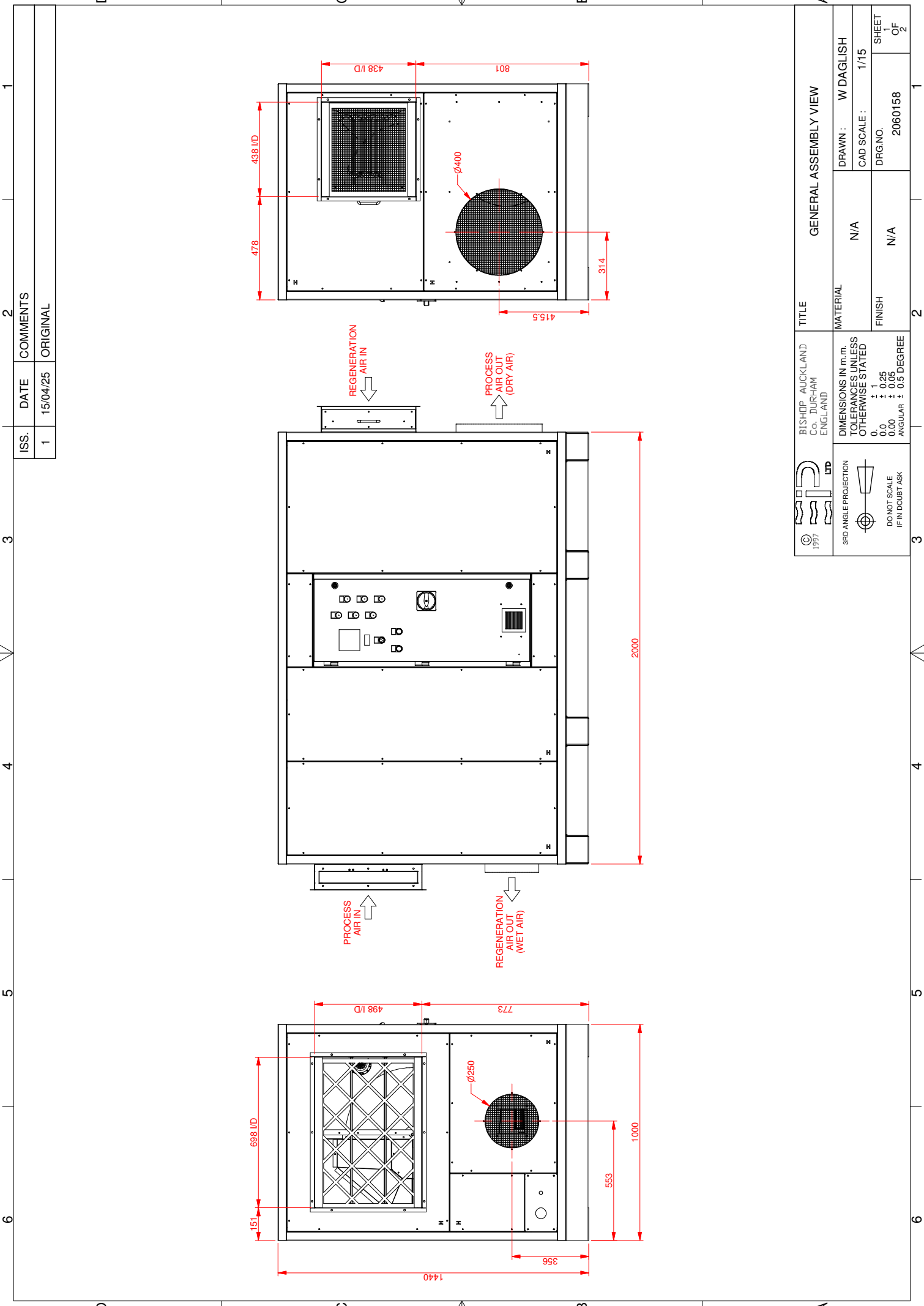

ISS.	DATE	COMMENTS
1	15/04/25	ORIGINAL

GENERAL ASSEMBLY VIEW			
BISHOP AUCKLAND Co. DURHAM ENGLAND	TITLE	GENERAL ASSEMBLY VIEW	
 3RD ANGLE PROJECTION DO NOT SCALE IF IN DOUBT/ASK	MATERIAL	N/A	DRAWN : W DAGLISH 1/15
	FINISH	N/A	DRG.NO. 2060158
DIMENSIONS IN m.m. TOLERANCES UNLESS OTHERWISE STATED 0.0 ± 1 0.00 ± 0.25 0.00 ± 0.05 ANGULAR ± 0.5 DEGREE		SHEET 1 OF 2	

ISS.	DATE	COMMENTS
1	15/04/25	ORIGINAL

REGENERATION INLET MOUNTING POINTS

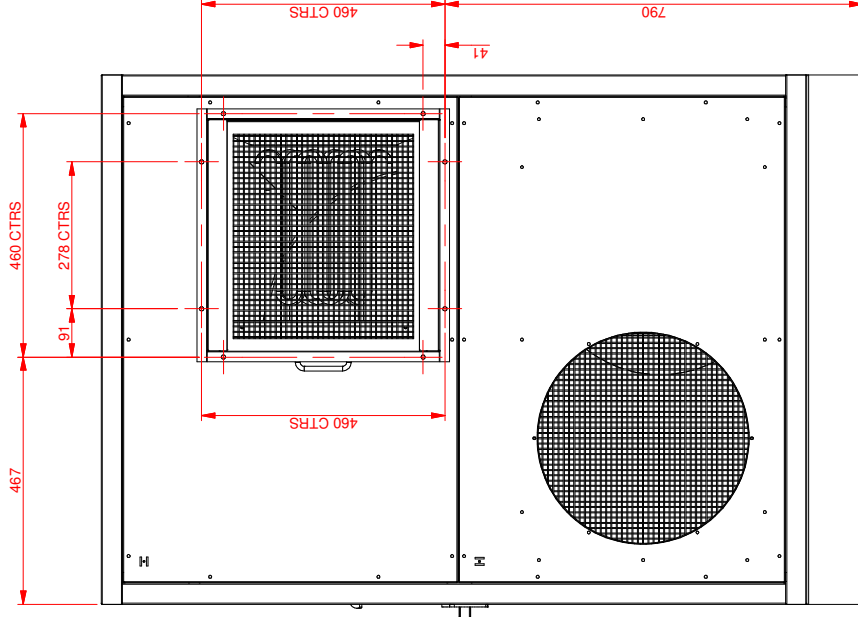

8 OFF M5 FIXINGS

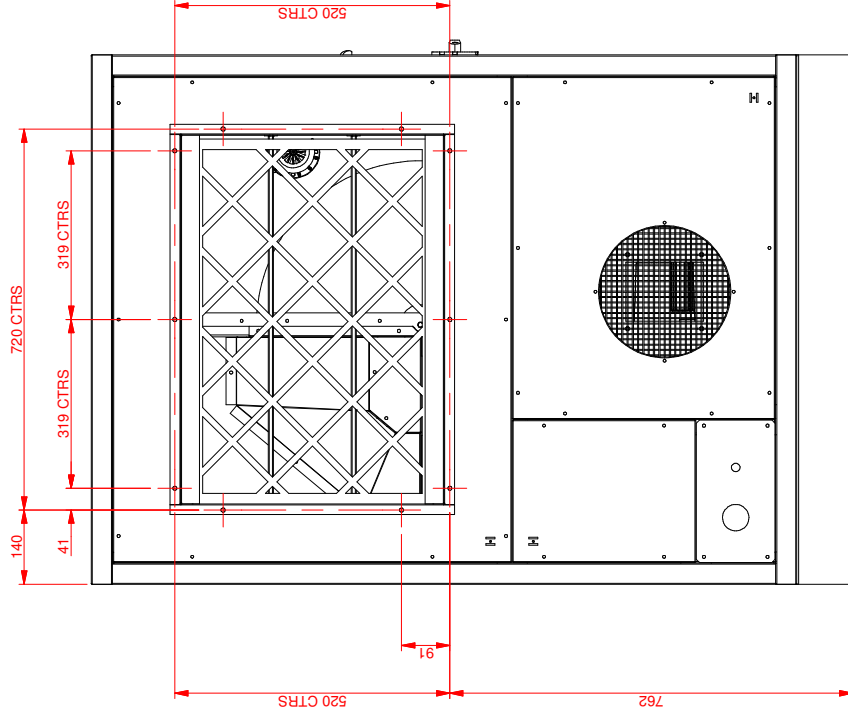

PROCESS INLET MOUNTING POINTS

10 OFF M5 FIXINGS

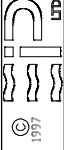

 BISHOP AUCKLAND Co. DURHAM ENGLAND LTD	TITLE	GENERAL ASSEMBLY VIEW	
	MATERIAL	N/A	DRAWN : W DAGLISH CAD SCALE : 1/10
	FINISH	N/A	DRG.NO. 2060158 SHEET 2 OF 2
DIMENSIONS IN m.m. TOLERANCES UNLESS OTHERWISE STATED 0.0 ± 1 0.0 ± 0.25 0.00 ± 0.05 ANGULAR ± 0.5 DEGREE			
3RD ANGLE PROJECTION  DO NOT SCALE IF IN DOUBT ASK			

ISS.	DATE	COMMENTS
1	15/04/25	ORIGINAL

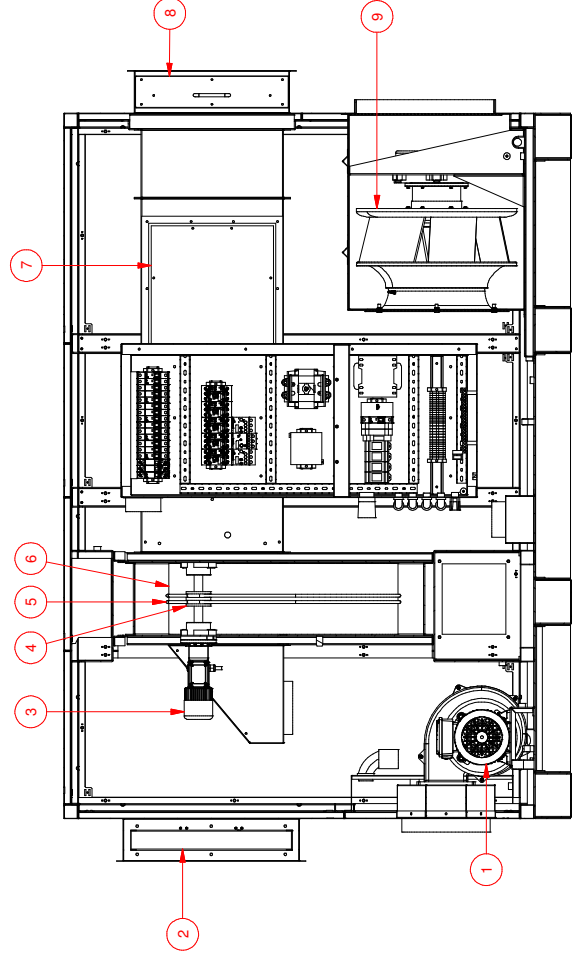

SECTION A-A
SCALE 1/15

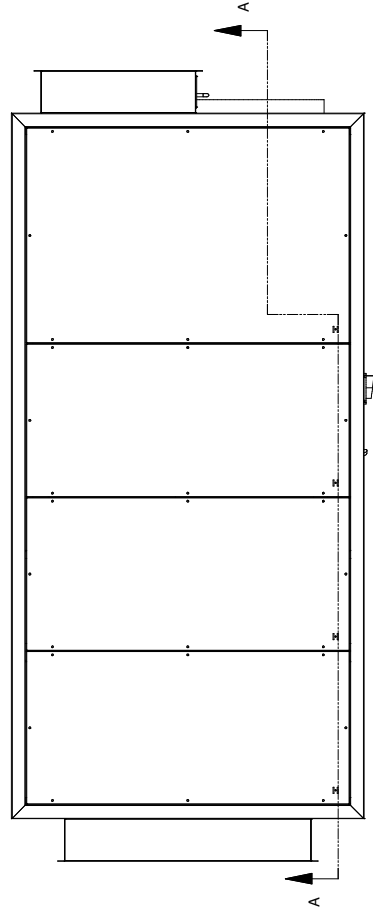

Parts List			
ITEM	PART NUMBER	DESCRIPTION	QTY
1	3040298	REGENERATION FAN	1
2	2060094	PROCESS AIR FILTER	1
3	3947019	DRIVE MOTOR	1
4	2060097	BELT PULLEY	1
5	3050561	DESICCANT ROTOR BELT	2
6	3020703	DESICCANT ROTOR	1
7	2060116	ELECTRIC HEATERS	1
8	3110395	REGENERATION FILTER	1
9	3947026	PROCESS FAN	1

	BISHOP AUCKLAND Co. DURHAM ENGLAND		TITLE INTERNAL VIEW	
	DIMENSIONS IN m.m. TOLERANCES UNLESS OTHERWISE STATED		MATERIAL N/A	DRAWN : W DAGLISH
	± 1 0.0 0.00 ANGULAR ± 0.5 DEGREE	± 0.25 ± 0.05 ± 0.5 DEGREE	FINISH N/A	CAD SCALE : 1/15 DRG.NO. 2060159

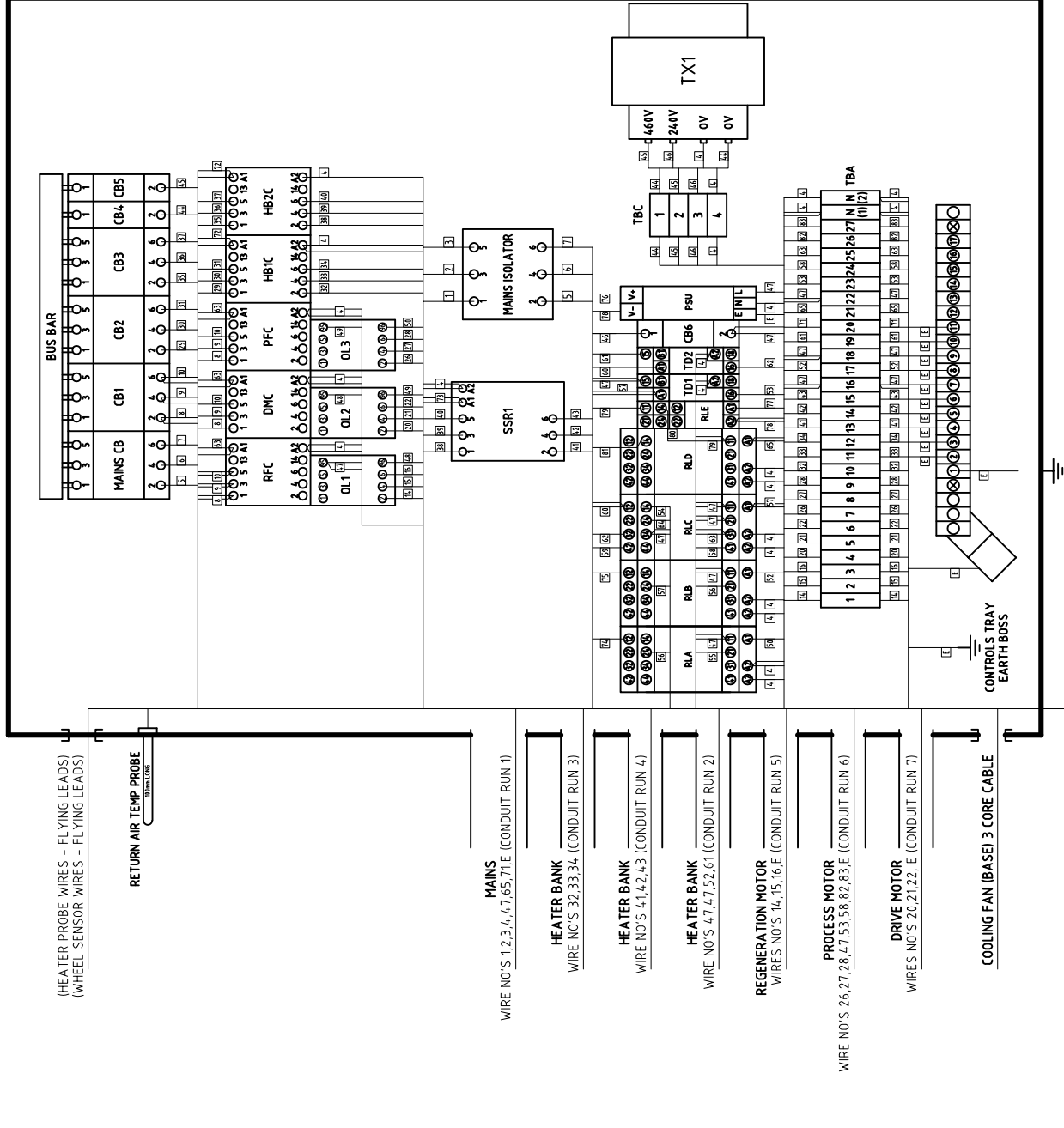
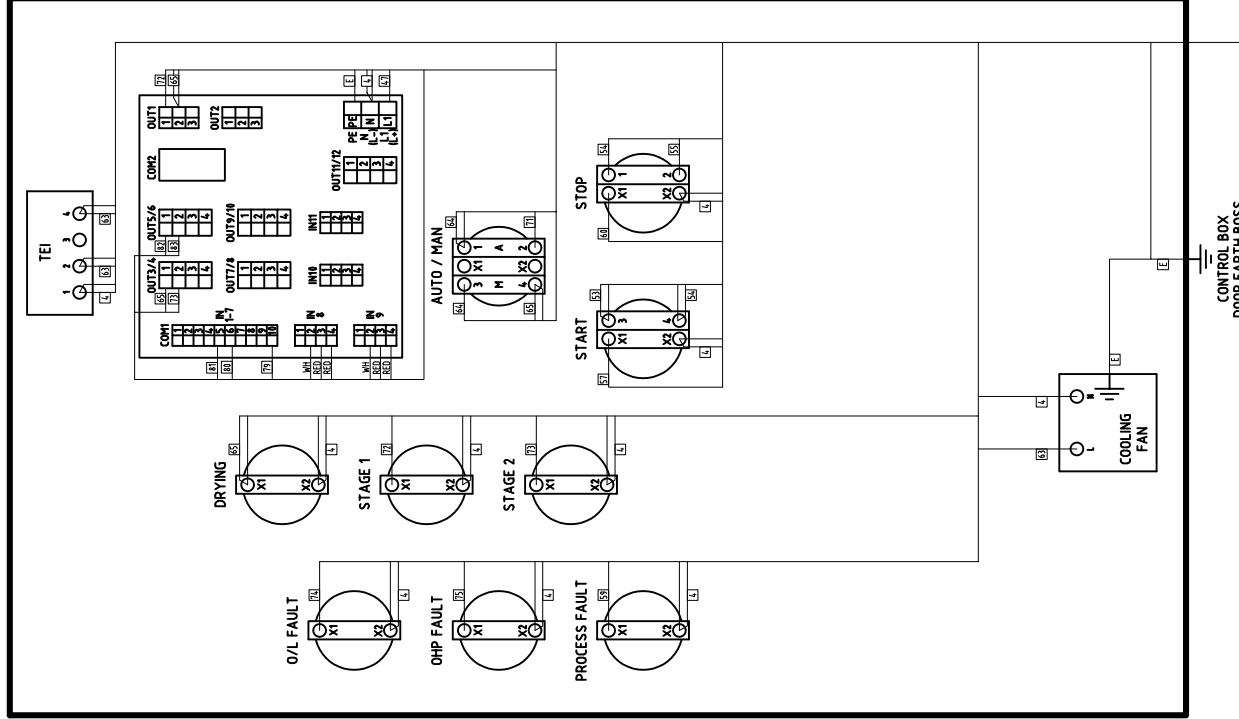

(HEATER PROBE WIRES - FLYING LEADS)
(WHEEL SENSOR WIRES - FLYING LEADS)

RETURN AIR TEMP PROBE
THRU LOW

MAINS
WIRE NO'S 1,2,3,4,47,65,71,E (CONDUIT RUN 1)

HEATER BANK
WIRE NO'S 32,33,34 (CONDUIT RUN 3)

HEATER BANK
WIRE NO'S 41,42,43 (CONDUIT RUN 4)

HEATER BANK
WIRE NO'S 47,47,52,61 (CONDUIT RUN 2)

REGENERATION MOTOR
WIRES NO'S 14,15,16,E (CONDUIT RUN 5)

PROCESS MOTOR
WIRE NO'S 26,27,28,47,53,58,82,83,E (CONDUIT RUN 6)

DRIVE MOTOR
WIRES NO'S 20,21,22,E (CONDUIT RUN 7)

COOLING FAN (BASE) 3 CORE CABLE

CONTROL BOX
DOOR EARTH BOSS

CONTROL BOX
BASE EARTH BOSS



LIMITED
BISHOP AUCKLAND
ENGLAND

TITLE
DD3000 ELECTRICAL - 4.60V / 60HZ

DIMENSIONS IN m.m.
TOLERANCES UNLESS
OTHERWISE STATED
0.0 ± 1
0.0 ± 0.25
0.0 ± 0.05
ANGULAR ± 0.5 DEGREE

MATERIAL
N/A

3RD ANGLE PROJECTION
DO NOT SCALE
IF IN DOUBT ASK

FINISH
N/A

DRG.NO.
5010416

DRAWN : W DAGLISH
CAD SCALE : N/A

SHEET
1 OF 2

ISSUE	DATE	AMENDMENTS
1	19/03/25	ORIGINAL
2	29/04/25	TEI TERMINALS UPDATED - WDA

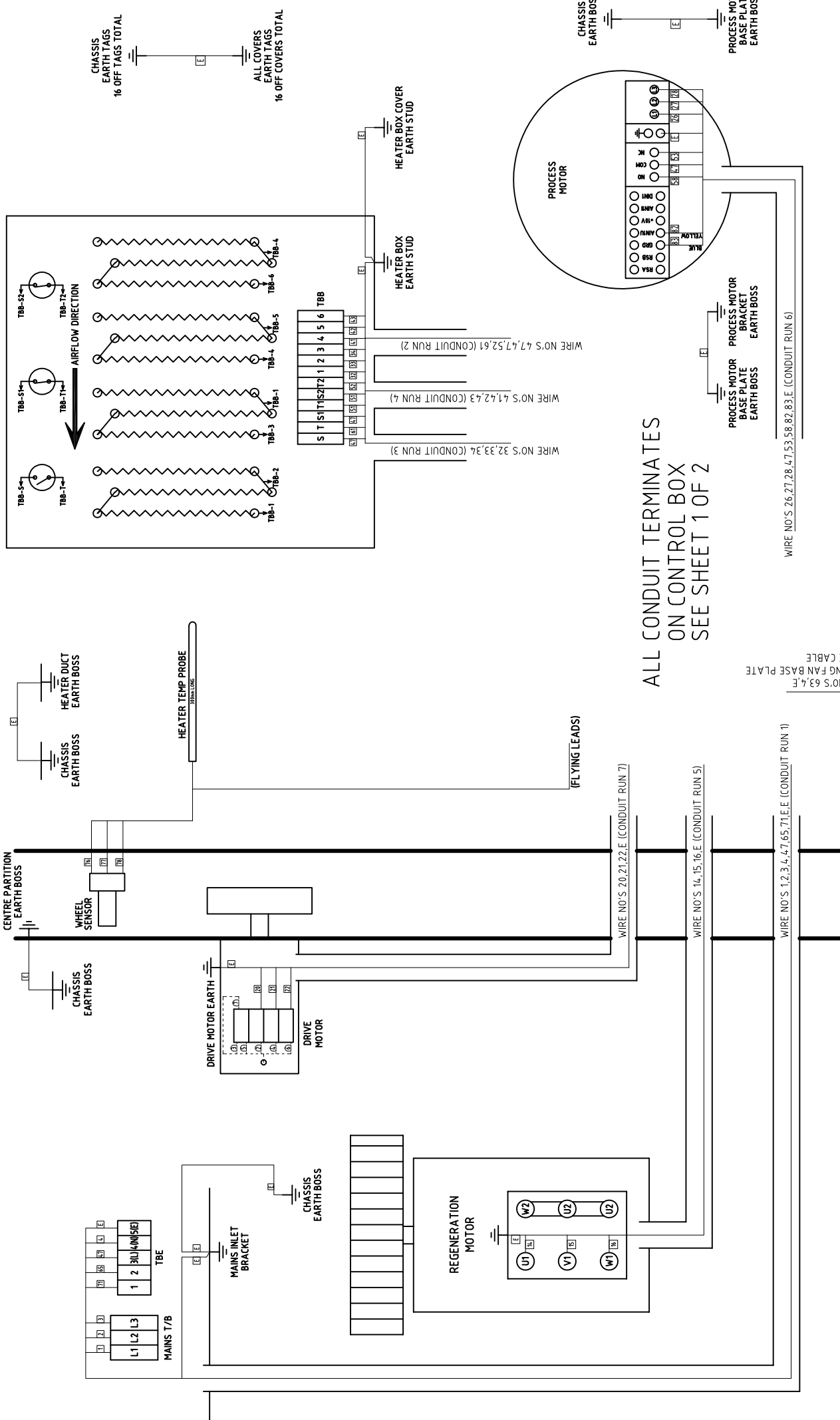

ALL CONDUIT TERMINATES ON CONTROL BOX SEE SHEET 1 OF 2

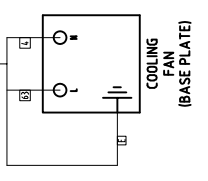

WIRE NO'S 26,27,28,47,53,58,82,83,E. (CONDUIT RUN 6)

PROCESS MOTOR BASE PLATE EARTH BOSS

PROCESS MOTOR BRACKET EARTH BOSS

PROCESS MOTOR BASE PLATE EARTH BOSS

PROCESS MOTOR BRACKET EARTH BOSS

WIRE NO'S 4,7,52,61 (CONDUIT RUN 2)

WIRE NO'S 4,4,2,3 (CONDUIT RUN 4)

WIRE NO'S 32,33,34 (CONDUIT RUN 3)

WIRE NO'S 2,0,21,22,E. (CONDUIT RUN 7)

WIRE NO'S 14, 15, 16,E. (CONDUIT RUN 5)

WIRE NO'S 1,2,3,4,7,65,71,E.E. (CONDUIT RUN 1)

CHASSIS EARTH BOSS

HEATER DUCT EARTH BOSS

CHASSIS EARTH BOSS

HEATER TEMP PROBE

HEATER BOX EARTH STUD

HEATER BOX COVER EARTH STUD

PROCESS MOTOR

CHASSIS EARTH BOSS

PROCESS MOTOR BASE PLATE EARTH BOSS

CHASSIS EARTH TAGS 16 OFF TAGS TOTAL

ALL COVERS EARTH TAGS 16 OFF COVERS TOTAL

ISSUE	DATE	AMENDMENTS
1	19/03/25	ORIGINAL
2	29/04/25	TEI TERMINALS UPDATED - WDA

		LIMITED BISHOP AUCKLAND ENGLAND	TITLE DD3000 ELECTRICAL - 460V / 60Hz
3RD ANGLE PROJECTION DO NOT SCALE IF IN DOUBT ASK	DIMENSIONS IN m.m. TOLERANCES UNLESS OTHERWISE STATED 0.0 ± 1 0.0 ± 0.25 0.0 ± 0.05 ANGULAR ± 0.5 DEGREE	MATERIAL N/A	FINISH N/A
DRAWN: W DAGLISH	CAD SCALE: N/A	DRG.NO. 5010416	SHEET 2 OF 2

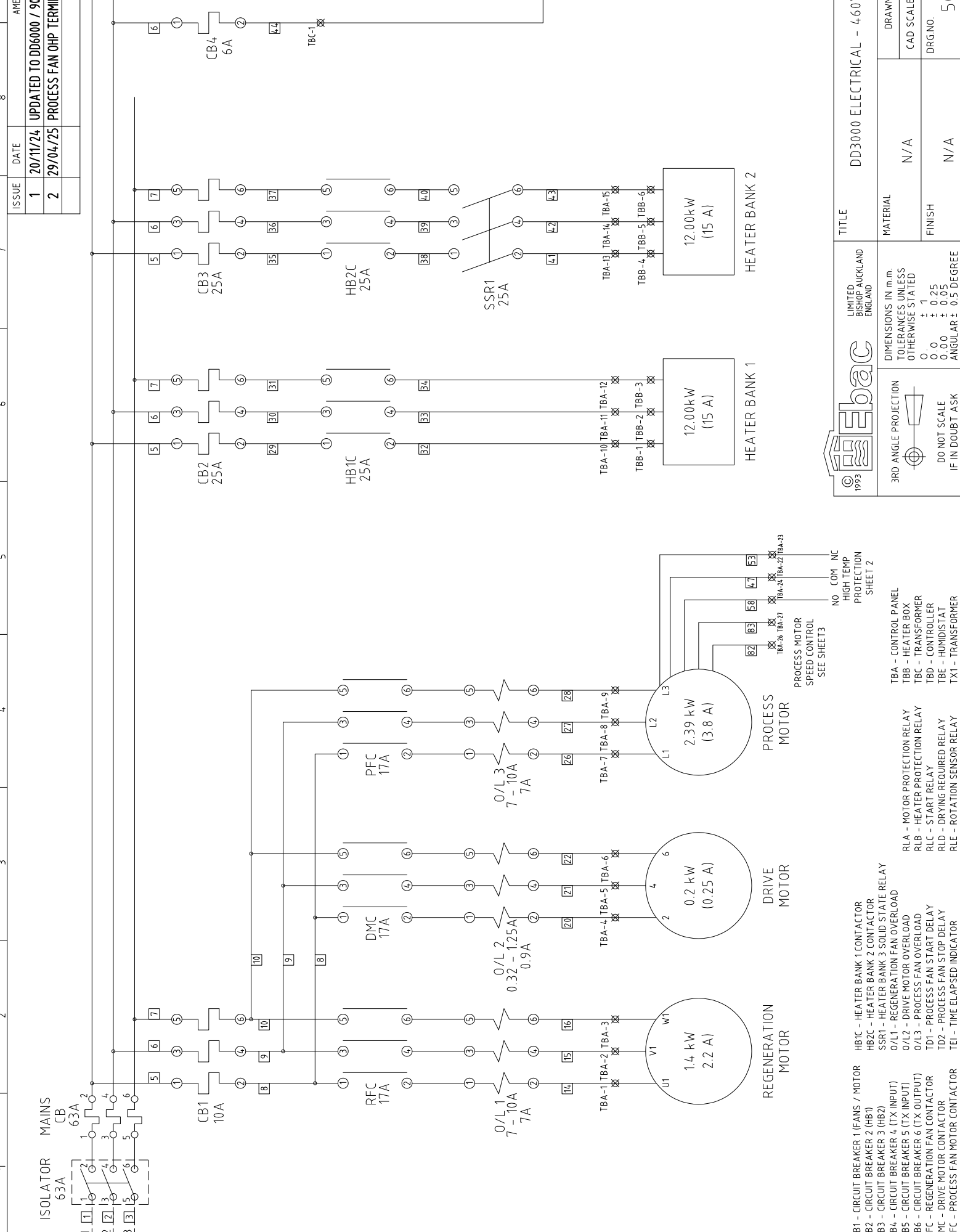

ISSUE	DATE	AMENDMENTS
1	20/11/24	UPDATED TO DD6000 / 9000 DESIGN STD - WDA
2	29/04/25	PROCESS FAN OHP TERMINAL ID'S UPDATED - WDA

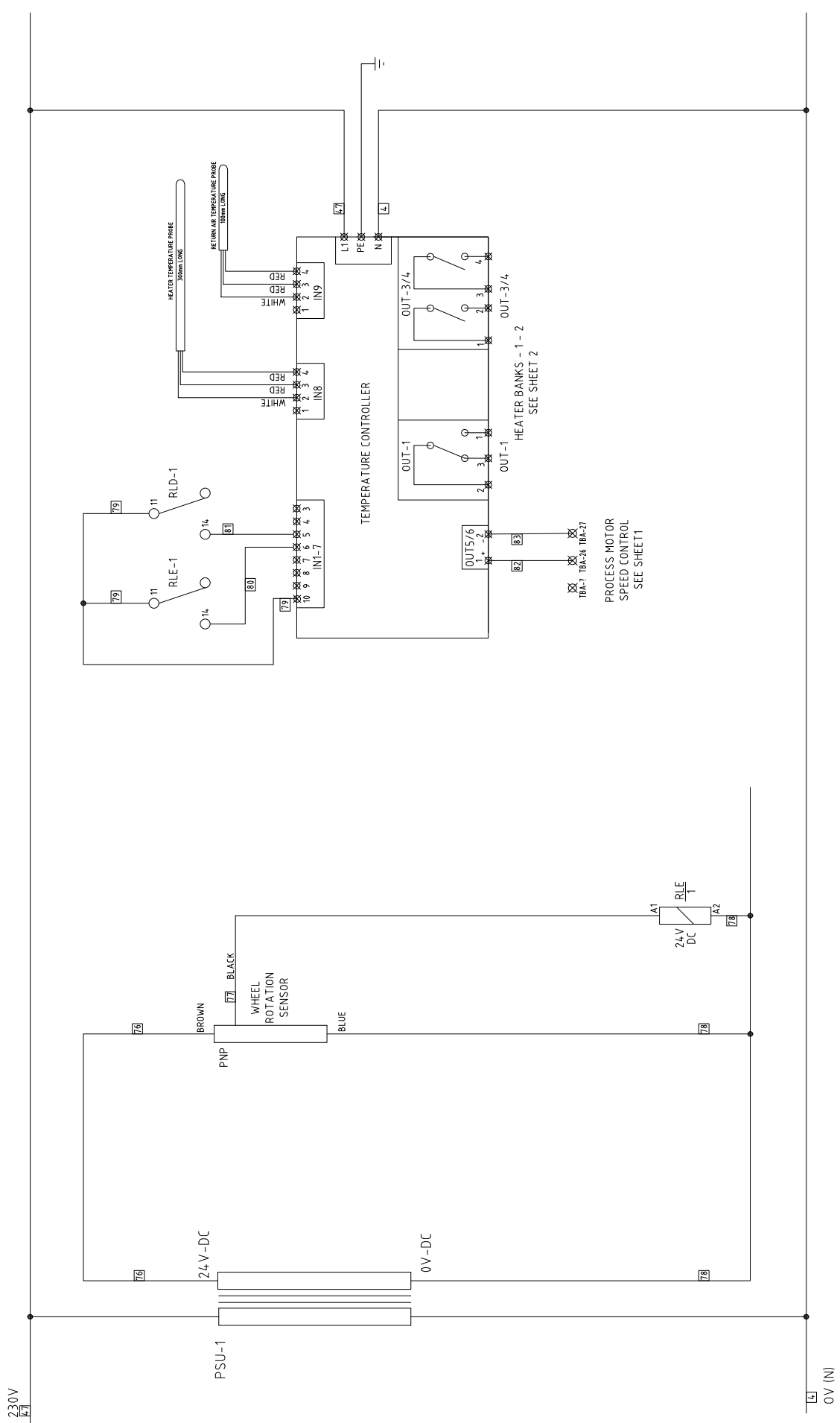

LIMITED BISHOP AUCKLAND ENGLAND		DD3000 ELECTRICAL - 460V / 60Hz	
DIMENSIONS IN mm TOLERANCES UNLESS OTHERWISE STATED		DRAWN : W DAGLISH	
3RD ANGLE PROJECTION		MATERIAL N/A	
DO NOT SCALE IF IN DOUBT ASK		FINISH N/A	
TBA - CONTROL PANEL		DRG.NO. 5020416	
TBB - HEATER BOX		SHEET 3 OF 3	
TBC - TRANSFORMER			
TBD - CONTROLLER			
TBE - HUMIDISTAT			
TX1 - TRANSFORMER			
RB1C - HEATER BANK 1 CONTACTOR			
RB2C - HEATER BANK 2 CONTACTOR			
SSR1 - HEATER BANK 3 SOLID STATE RELAY			
O/L1 - REGENERATION FAN OVERLOAD			
O/L2 - DRIVE MOTOR OVERLOAD			
O/L3 - PROCESS FAN OVERLOAD			
TD1 - PROCESS FAN START DELAY			
TD2 - PROCESS FAN STOP DELAY			
TE1 - TIME ELAPSED INDICATOR			
CB1 - CIRCUIT BREAKER 1 (FANS / MOTOR)			
CB2 - CIRCUIT BREAKER 2 (HB1)			
CB3 - CIRCUIT BREAKER 3 (HB2)			
CB4 - CIRCUIT BREAKER 4 (TX INPUT)			
CB5 - CIRCUIT BREAKER 5 (TX INPUT)			
CB6 - CIRCUIT BREAKER 6 (TX OUTPUT)			
RFC - REGENERATION FAN CONTACTOR			
DMC - DRIVE MOTOR CONTACTOR			
PFC - PROCESS FAN MOTOR CONTACTOR			
RLA - MOTOR PROTECTION RELAY			
RLB - HEATER PROTECTION RELAY			
RLC - START RELAY			
RLD - DRYING REQUIRED RELAY			
RLE - ROTATION SENSOR RELAY			